

Introduction

Devices that use surface-mount J-lead, quad flat pack (QFP), and ball-grid array (BGA)—including FineLine BGA™—packaging are now common on boards because they provide density, size, and cost benefits. However, a few precautions, however, are necessary to protect these devices from mechanical damage during transportation and storage. Following the guidelines in this application note will preserve the quality of Altera devices in J-lead, QFP, and BGA packages and ensure easier soldering. This application note discusses the following topics:

- Handling J-Lead and QFP Devices
- Transferring devices between tubes
- Transferring QFP and BGA devices without carriers between trays
- Dry-packing J-lead, QFP, and BGA devices
- Shipping J-lead, QFP, and BGA devices in boxes

Handling J-Lead & QFP Devices

To protect device leads and ensure proper operation, J-lead and QFP devices must be handled carefully when they are stored, shipped, and transferred. J-lead devices should be stored and shipped in tubes sealed with stoppers. When necessary, add foam inside the tubes for cushioning.

QFP devices in carriers should be shipped only inside tubes sealed with stoppers and, if necessary, with foam. Carriers are static-dissipative, molded plastic shells that hold QFP devices in a secure frame to prevent mechanical damage to device leads. These QFP devices can be programmed and erased inside carriers, and they can tolerate the 125° C baking required for dry packing. When handling QFP devices in carriers, do not touch the QFP device; only use finger cots to touch the carrier.



If you need to insert a QFP device into a carrier, contact Altera® Customer Marketing at (408) 544-7104. See the [QFP Carrier & Development Socket Data Sheet](#) for more information on QFP carriers.

QFP devices without carriers, QFP devices that have been extracted from carriers, and BGA devices should be stored and shipped only in trays sealed with straps. When extracting QFP devices from a carrier, use only Altera QFP extraction tools, and inspect the orientation and lead integrity of the devices. You should extract the devices and place them directly into trays.



For more information on handling QFP or BGA devices without carriers, see "Trays for QFP & BGA Devices without Carriers" on page 7 and "Straps for QFP & BGA Devices without Carriers" on page 9.

Tubes for J-Lead Devices & QFP Devices in Carriers

Altera-approved tubes protect J-lead and QFP devices in carriers from electrostatic discharge (ESD) and during transportation and storage. Use clear tubes to allow easy inspection of the contents' top-side markings. The tube material should be antistatic (with "antistatic" printed on it), and they should be stiff enough to prevent the tubes from warping, cracking, or developing burrs during normal handling. Follow these guidelines when transporting or storing devices in tubes:

- Keep tubes horizontal.
- Keep devices in "dead bug" orientation. See Figure 1.
- Ensure that devices do not overlap inside the tube.



When programming UV-erasable EPROM devices, use only conductive tubes.

Figure 1. Dead Bug vs. Live Bug Orientation

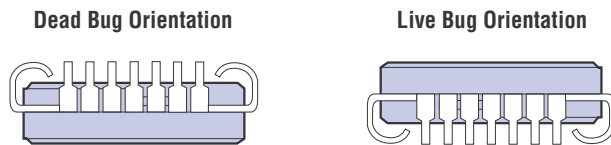
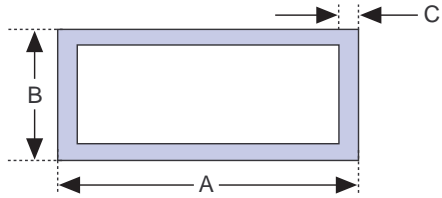

Figure 2 shows the tube dimensions required for each J-lead device. The tubes must match the dimensions of the device.

Figure 2. Tube Dimensions for J-Lead Device Antistatic Shipping Tube

Dimensions are shown in inches.



Pin Count	A	B	C	Shipping Length
20	0.480	0.260	0.025	20.00
28	0.580	0.260	0.025	20.00
44	0.780	0.260	0.025	20.25
68	1.100	0.280	0.035	20.00
84	1.300	0.280	0.035	20.25

Table 1 lists the part numbers for Altera-approved tubes for J-lead devices.

Table 1. Antistatic Tube Part Numbers for J-Lead Devices <i>Note (1)</i>		
Pin Count	Altera Reference Part Number	Tube Capacity (Devices)
20	E20-03708-00	49
28	E20-02078-00	39
44	E20-05952-00	26
68	E20-04431-00	18
84	E20-04740-00	15

Note:

(1) To order tubes, contact your local sales representative.

Table 2 lists the part numbers for Altera-approved tubes for QFP devices in carriers.

Pin Count	Package Dimensions (mm)	Tube Capacity (QFP Devices in Carriers)	Altera Reference Part Number
100	14 × 20	23	E20-02080-00
160	28 × 28	14	E20-04743-00
208	28 × 28	14	E20-04743-00
240	32 × 32	12	E20-04800-00
304	40 × 40	10	E20-04783-00

Note:

(1) To order tubes, contact your local sales representative.



See "Transferring Devices between Tubes" on page 10 for information on how to transfer devices between tubes.

Stoppers for J-Lead & QFP Devices in Carriers

Stoppers seal tubes and protect J-lead and QFP devices in carriers against mechanical damage and ESD. Altera uses black stoppers that match the tube dimensions. Follow these guidelines when inserting stoppers:

- Seat stoppers firmly into both ends of the tube before transporting or storing devices.
- Push stopper teeth fully inside the tube, with the grip extending outside for easy removal. Do not insert the stopper completely inside the tube. See Figure 3.
- Insert foam between the parts and stopper to prevent devices from moving inside an incompletely filled tube.

Figure 3. Stopper Properly Inserted into a Tube

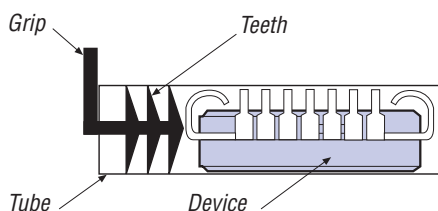

To reduce the risk of damaged leads, some special stoppers are designed to fit into a tube in only one way. Inserting these special stoppers correctly, with the grip in the same direction as the leads, is especially important. See [Figure 4](#).

Figure 4. Proper Orientation of Special Stoppers

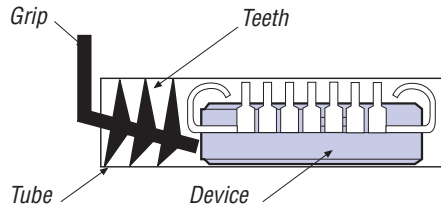

[Table 3](#) lists the part numbers for Altera-approved black stoppers for J-lead devices.

Table 3. Black Stopper Part Numbers for J-Lead Devices <i>Note (1)</i>	
Pin Count	Manufacturer Part Number
20	K-VT0236-25
28	K-VT0236-12
44	KBR-044
68	KBR-068
84	KBR-084

Note:

(1) To order stoppers, contact your local sales representative.

To prevent damage to leads during shipping, tubes containing 208-, 240-, and 304-lead power quad flat pack (RQFP) packages in carriers should have modified stoppers. Although these stoppers have a notch cut out of them, they are used just like other stoppers. See [Figure 5](#).

Figure 5. Notched Stoppers for Tubes of RQFPs in Carriers

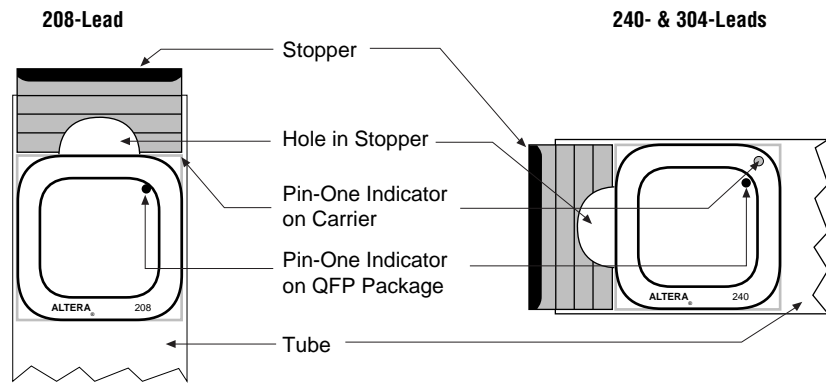

Table 4 lists the part numbers for Altera-approved black stoppers for QFP devices in carriers.

Table 4. Black Stopper Part Numbers for QFP Devices in Carriers *Note (1)*

Pin Count	Altera Part Number
100	E20-04739-00
160	E20-04764-00
208	E20-04764-00
240	E20-04765-00
304	E20-04766-00

Note:

(1) To order stoppers, contact your local sales representative.

Foam for J-Lead Devices & QFP Devices in Carriers

Foam provides extra cushioning and restricts movement inside the tube to prevent device pins from bending. To support the devices evenly, the foam should be nearly as wide as the tubes. Foam should not be used in any full tube containing special stoppers that are shown in Figure 4 on page 5. When used, foam should be placed at each end of the tube between the stoppers and devices (see Figure 6).

Foam should be antistatic, non-corrosive, and free of contaminants. Place foam in tubes containing:

- A gap inside the tube measuring 1/4 inch or greater (for both J-Lead and QFP devices in carriers)
- Plastic J-lead chip carrier (PLCC) devices with 44 or more pins (full tubes containing PLCC devices with 28 or fewer pins generally do not need foam)
- Ceramic J-lead chip carrier (JLCC) devices

Figure 6. Stoppers, Foam & Devices in a Tube

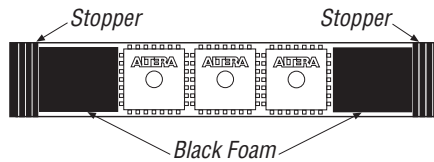

Trays for QFP & BGA Devices without Carriers

To hold QFP devices without carriers or BGA devices, use only Altera-approved trays—full-sized Peak Plastic Corporation trays and 1/3-sized ITW Camtex trays. When stacking trays for transportation or storage, follow these guidelines:

- Seal stacks of trays with straps.
- Make sure all trays are of the same revision. The revision is indicated by the letter following “Rev.”
- Align all pin-one chamfers on the trays together. See [Figure 7](#).
- Align trays and ensure that they are seated properly before strapping them together.
- Stack RQFP trays no higher than 5 trays (i.e., 4 trays containing devices and 1 cover tray).
- Stack plastic quad flat pack (PQFP) and BGA trays no higher than 7 trays (i.e., 6 trays containing devices and 1 cover tray).

Figure 7. Properly Aligned Peak Trays

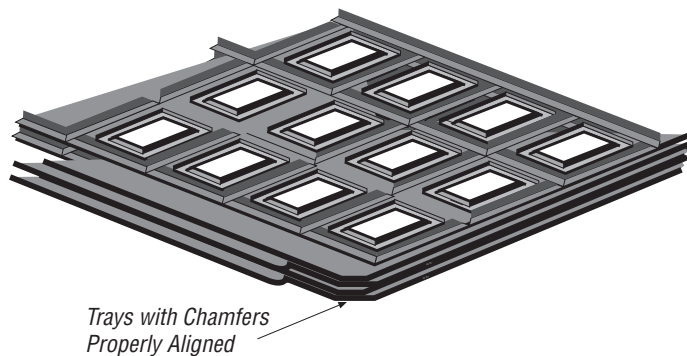

All of the full-size Peak Plastic Corporation trays used by Altera can withstand temperatures of at least 150° C. These heat-resistant trays are not only more rigid, but they also can endure baking at 125° C, which is the recommended temperature for dehydrating moisture-sensitive devices. Table 5 lists the part numbers for Altera-approved, low-profile trays.

Table 5. Altera-Approved Trays for QFP & BGA Devices (Part 1 of 2) Note (1)

Package	Package Dimensions (mm)	Tray Capacity (Devices)	Peak Part Number (2)	Altera Reference Part Number
32-pin TQFP (3)	7 × 7	250	ND-0707-1.0-1025- <i>n</i>	E20-03548-00
44-pin TQFP	10 × 10	160	ND-1010-1.0-0820- <i>n</i>	E20-03549-00
44-pin QFP (4)	10 × 10	96	NH-1010-2.0-0616- <i>kn</i>	E20-03550-00
100-pin TQFP	14 × 14	90	ND-1414-1.0-0615- <i>n</i>	E20-03551-00
100-pin QFP	14 × 20	66	ND-1420-2.7-0611- <i>n</i>	E20-03544-01
132-pin QFP	JEDEC	36	NX-PQFP-132-0409- <i>n</i>	E20-03355-00
144-pin TQFP	20 × 20	60	ND-2020-1.4-0512- <i>n</i>	E20-03557-00
160-pin QFP	28 × 28	24	ND-2828-3.5-0308- <i>n</i>	E20-04746-00
208-pin QFP	28 × 28	24	ND-2828-3.5-0308- <i>n</i>	E20-04746-00
240-pin QFP	32 × 32	24	ND-3232-3.4-0308- <i>n</i>	E20-04267-00
304-pin QFP	40 × 40	12	ND-4040-3.8-0206- <i>n</i>	E20-03552-00
100-pin FineLine BGA	11 × 11	176	NH-BG111-1.5-0822- <i>n</i>	E20-04481-00
225-pin BGA	27 × 27	40	NX-BG2727-2.0-0410- <i>n</i>	E20-03553-00
256-pin BGA	27 × 27	40	NX-BG2727-2.0-0410- <i>n</i>	E20-03553-00
256-pin FineLine BGA	17 × 17	90	NH-BG1717-1.5-0615- <i>n</i>	E20-05939-00
356-pin BGA	35 × 35	24	NH-BG3535-2.2-0308- <i>n</i>	E20-04430-00

Table 5. Altera-Approved Trays for QFP & BGA Devices (Part 2 of 2) *Note (1)*

Package	Package Dimensions (mm)	Tray Capacity (Devices)	Peak Part Number (2)	Altera Reference Part Number
484-pin FineLine BGA	23 × 23	60	NX-BG2323-1.5-0512- <i>n</i>	E20-04430-00
600-pin BGA	45 × 45	12	NX-BG4545-2.2-0206- <i>n</i>	E20-04564-00
652-pin BGA	45 × 45	12	NX-BG4545-2.2-0206- <i>n</i>	E20-04564-00
672-pin FineLine BGA	27 × 27	40	NX-BG2727-2.0-0410- <i>n</i>	E20-03553-00

Notes:

- (1) To order 100 trays or less, contact EcoTech at (408) 988-2050. To order more than 100 trays, contact Peak Plastic Corporation (USA) at (408) 934-2480.
- (2) For trays that can withstand 180° C, *n* = 8. For trays that can withstand 150° C, *n* = 6.
- (3) TQFP: thin quad flat pack.
- (4) The current tray (Peak part number NH-1010-2.0-0616-*kn*) for this package is compatible with the old tray (Peak part number ND-1010-2.0-0616-*n*). Although Altera will eventually retire the old tray, both trays can safely be used together.

Straps for QFP & BGA Devices without Carriers

Straps secure trays and prevent devices from jostling during transportation and storage. To hold trays together during transportation, Altera recommends using at least 1/2-inch-wide polypropylene straps that can withstand temperatures up to 130° C in case you need to bake the devices before mounting. When storing devices, Altera recommends using either Velcro or polypropylene straps.

Velcro straps that are 20 inches in length are sufficiently long to bind stacks of 2 to 7 trays for storage. Follow these guidelines when you strap trays together for shipping:

- Use only heat-sealed polypropylene straps. (Although Velcro straps can hold trays together during storage, they lack the strength required to hold trays together during transportation.)
- Set the tension on the strapping machine high enough to prevent straps from sliding off a stack of trays.
- Secure three heat-sealed polypropylene straps across the width of the stack, placing two of the straps in the indentations on the long sides of the trays. See [Figure 8](#).
- Secure one polypropylene strap across the length of the tray.
- Remove straps with a knife to prevent jostling devices in the trays.



Do not use rubber bands, masking tape, string, or other similar material in place of Velcro or polypropylene straps.

Figure 8. Properly Secured Polypropylene Straps on a Stack of Trays

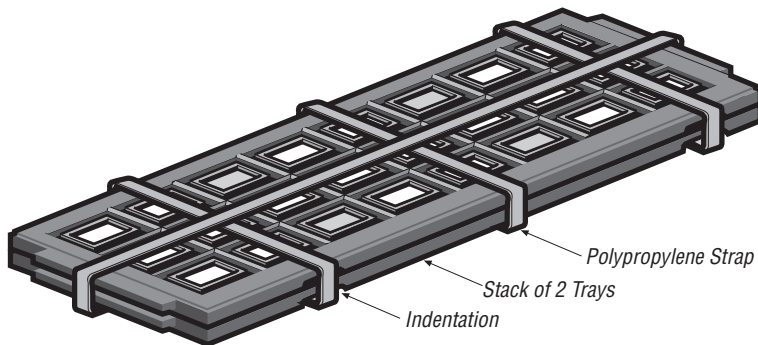

Transferring Devices between Tubes

To prevent leads from bending on tube edges, follow these steps when transferring J-lead devices and QFP devices in carriers from one tube to another:

1. Use a metal or plastic sleeve to line up tube ends (see [Figure 9](#)). If you do not have a sleeve, carefully line up the tube ends.
2. Tilt the tubes so that the devices slide from one tube to the other. Do not shake or vibrate the tubes.

Figure 9. Sleeve for Tube-to-Tube Transfer

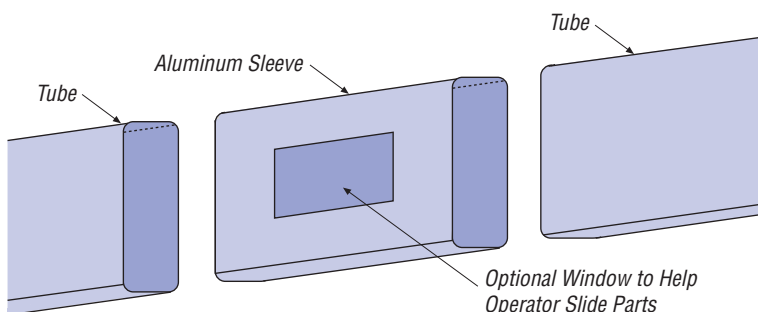

Transferring QFP & BGA Devices without Carriers between Trays

Altera recommends using automated pick-and-place machines in an ESD-protected environment to transfer QFP or BGA devices between trays. If you need to transfer these devices manually, follow these guidelines:

- Work in an ESD-protected environment.
- Use ground straps and finger cots.
- Use only vacuum pens to transfer QFP or BGA devices manually. Vacuum pens should be able to maintain their vacuum for at least four seconds. See [Figure 10](#).
- Transfer devices right-side-up over a table; then release the vacuum only after the device is properly oriented and seated in the tray.
- Do not allow QFP device leads to contact the tray.

Figure 10. Transferring a QFP Device Using a Vacuum Pen

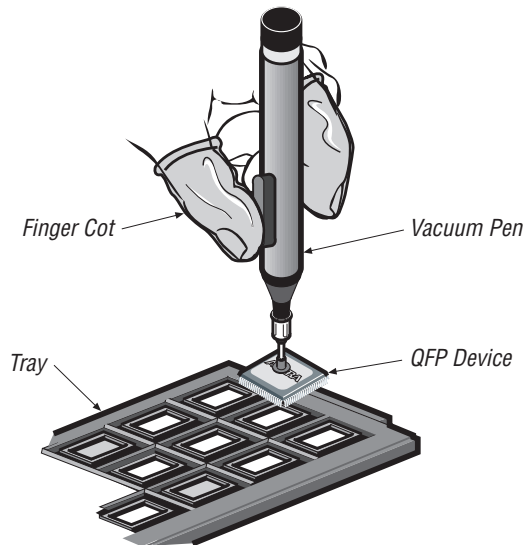

Dry Packing J-Lead, QFP & BGA Devices

Dry packing is a method of packing moisture-sensitive devices for shipment. Risk to moisture-sensitive devices can occur when the high soldering temperatures of the reflow process suddenly heat any moisture absorbed by a plastic package. Although many of Altera's devices are not sensitive to moisture, Altera has adopted dry packing as a standard practice for moisture-sensitive devices to eliminate all risk of moisture. In addition, Altera can dry-pack other devices upon request. During dry packing, devices are first baked to remove any existing moisture and then packed and vacuum-sealed in moisture-barrier bags. Table 6 lists the contents of a typical dry pack.

<i>Table 6. Dry Pack Contents</i>	
Item	Specification
Moisture-barrier bag	MIL-B-81705C, Type 1 or equivalent
Desiccant	MIL-D-3464, Type II or equivalent
Humidity-indicator card	Compliant with MIL-I-8835A
Labels	ID label and caution label

To maintain a moisture-free environment, follow these guidelines after receiving dry-packed devices from Altera:

- Open bags as close to the seal as possible to leave enough of the bag for resealing.
- Reseal bags after opening to minimize exposure to moisture.
- Inspect all dry packs for potential leaks in the seals or bags.
 - If a leak exists and the humidity-indicator card shows an unacceptable humidity level (i.e., the 20% dot has started to turn pink), rebake the devices.
 - If a leak exists but the humidity-indicator card shows an acceptable humidity level (i.e., the 20% dot is blue with no pink), reseal the devices in an undamaged bag.
- Check that the humidity-indicator card shows acceptable humidity after opening dry packs. If the card shows an unacceptable humidity level, rebake the devices.
- Store dry packs in conditions $< 40^{\circ}\text{C}$ and $< 90\%$ relative humidity.

In addition, Altera lists the floor life on every dry pack label. The floor life is the length of time a device can be exposed to a factory environment ($< 30^{\circ}\text{C}$ and $< 60\%$ relative humidity) after the device has been removed from the bag and before it is mounted. Parts that are not dry packed have an unlimited floor life but should be stored at a proper environment ($< 30^{\circ}\text{C}$ and $< 85\%$ relative humidity). Rebake devices prior to mounting if the interval between opening a dry pack and mounting the devices onto a board exceeds the floor life of the devices.

Distributors have an additional allotment of time beyond the labeled floor life. Six hours are available for products with a 24-hour floor life, and 24 hours are available for products with a 168-hour or one-year floor life. These time allotments allow for programming and repacking as needed.

Altera recommends the following guidelines when dry-packing devices:

- When transferring parts to new dry pack bags, operators should remember to copy the floor life and expiration date accurately to the new dry-pack labels.
- Bake QFP or BGA devices in strapped heat-resistant trays at 125° C for at least 12 hours.
- Bake J-lead devices in heat-resistant tubes at 125° C for at least 12 hours. If you lack heat-resistant tubes, bake J-lead devices on a cookie sheet in dead-bug orientation.
- Use heat-sealed bags that are resistant to punctures and abrasion.
- Use foam covers or bubble wrap around a stack of trays inside the moisture-barrier bag to avoid punctures.
- Seal bags with a vacuum-operated bag-sealing machine. Relax the vacuum enough to prevent the tube or tray from puncturing the bag.
- Replace the desiccant and humidity indicator card if the dry pack is open for longer than one hour.
- Use at least one unit of desiccant per dry pack.
- Zip-lock and dry-pack bags should not be used for longer than one week.

Dry Pack Sizes

Table 7 shows the available dry pack sizes. Altera uses heavy-duty, 6" × 24", 6" × 30", and 10" × 30" bags for dry-packing tubes. Altera's bags for trays are 10" × 20".

Package	Lead Count	Quantity per Container (1)	Type of Container	Maximum Containers per Bag	Maximum Devices per Bag
PLCC	84	15	Tube	10	150
QFP	100	66	Tray	6	396
	100	23	Carriers and Tubes	10	230
	132	36	Tray	6	216
	160	24	Tray	6	144
	160	14	Carriers and Trays	10	140
	208	24	Tray	6	144
	208	14	Carriers and Trays	10	140

Table 7. Dry Pack Sizes (Part 2 of 2)

Package	Lead Count	Quantity per Container (1)	Type of Container	Maximum Containers per Bag	Maximum Devices per Bag
RQFP	208	24	Tray	4	96
	208	14	Carriers and Trays	10	140
	240	24	Tray	4	96
	240	12	Carriers and Trays	10	120
	304	12	Tray	4	48
	304	10	Carriers and Trays	10	100
TQFP	32	250	Tray	6	1,500
	44	160	Tray	6	960
	100	90	Tray	6	540
	144	60	Tray	6	396
FineLine BGA	100	176	Tray	6	1,056
BGA	225	40	Tray	6	240
	256	40	Tray	6	240
FineLine BGA	256	90	Tray	6	540
BGA	356	24	Tray	4	96
FineLine BGA	484	60	Tray	4	240
BGA	600	12	Tray	6	72
	652	12	Tray	4	48
FineLine BGA	672	40	Tray	4	160

Note:

(1) For trays, each listed quantity per container includes only trays filled with devices. An additional empty tray is required as a cover.

Shipping J-Lead, QFP & BGA Devices in Boxes

When shipping trays or tubes of devices, only use boxes that have passed the ASTM D776 test for shipping containers. To protect against ESD, Altera recommends that you use boxes with an internal, conductive finish. You should add filler material to boxes to cushion the contents and prevent trays or tubes from shifting position during shipping. Boxes should contain enough filler material to prevent stoppers from falling out of tubes when jostled. Filler material should meet the following standards:

- Filler materials should be antistatic and non-corrosive.
- Filler materials should not crumble, flake, powder, outgas, or shed.
- Filler materials should not scratch or puncture the trays, tubes, or dry-pack bags.

To order foam filler, contact Pacific Southwest Container at (800) 772-0444. To order bubble wrap, trays, or dry packing supplies, contact EcoTech at (408) 988-2050.

Ordering

Table 8 lists Altera-approved packing media and suppliers.

Material	Supplier
Tubes and stoppers	Altera
Small volumes of QFP or BGA trays (100 trays or less)	Ecotech 3281 Keller Street Santa Clara, CA 95051 Telephone: (408) 988-2050 Fax: (408) 988-4009
Large volumes of QFP or BGA trays (more than 100 trays)	Peak Plastics USA 2345 Spring Street Redwood City, CA 94063 Telephone: (415) 369-2544 Fax: (415) 369-2561
Pin-grid array (PGA) trays	Ecotech Telephone: (408) 988-2050
ESD Velcro straps	Com-Kyl Telephone: (408) 734-9660
0.5"-wide, polypropylene, heat-sealed straps (E30-04766)	Southbay Packaging Telephone: (408) 998-1131
Tray-strapping machines (using polypropylene, heat-sealed straps) or other dry-packing equipment	Kent Landsberg Telephone: (408) 436-8010 StraPack (Sivaron Model S-669, D-52, and AQ-7))
Foam packaging	Pacific Southwest Container Telephone: (800) 772-0444
Bubble wrap	Ecotech Telephone: (408) 988-2050
Vacuum pens	Virtual Industries Telephone: (800) 530-8377 info@virtual-ii.com

References

JEDEC. *Guidelines for the Packing, Handling, and Repacking of Moisture-Sensitive Components* (EIA/JEP124). Electronic Industries Association, 1995.

JEDEC, IPC, and Electronic Industries Association, Inc. *Moisture/Reflow Sensitivity Classification for Plastic, Integrated-Circuit, Surface-Mount Devices* (J-STD-020). 1996.

Electronic Industries Association, Inc. *Requirements for Handling Electrostatic-Discharge Sensitive (ESDS) Devices* (EIA-625). Electronic Industries Association, 1994.

JEDEC. *Symbol and Labels for Moisture-Sensitive Devices* (EIA/JEP113-A). Electronic Industries Association, 1995.



101 Innovation Drive
San Jose, CA 95134
(408) 544-7000
<http://www.altera.com>
Applications Hotline:
(800) 800-EPLD
Customer Marketing:
(408) 544-7104
Literature Services:
(888) 3-ALTERA
lit_req@altera.com

Altera and FineLine BGA are trademarks of Altera Corporation. Altera acknowledges the trademarks of other organizations for their respective products or services mentioned in this document, specifically: Velcro is a registered trademark of Velcro Industries B.V. Altera products are protected under numerous U.S. and foreign patents and pending applications, maskwork rights, and copyrights. Altera warrants performance of its semiconductor products to current specifications in accordance with Altera's standard warranty, but reserves the right to make changes to any products and services at any time without notice. Altera assumes no responsibility or liability arising out of the application or use of any information, product, or service described herein except as expressly agreed to in writing by Altera Corporation. Altera customers are advised to obtain the latest version of device specifications before relying on any published information and before placing orders for products or services.

Copyright © 1999 Altera Corporation. All rights reserved.

