

This application note describes the thermal composite flip chip molded ball-grid array (FCmBGA) package for the Arria® V device family.

FCmBGA improves board real-estate use by allowing closer spacing between passive components and the flip chip die, providing better warpage control for thin core substrates, and improving solder joint reliability.

This application note includes the following sections:

- “FCmBGA Overview”
- “Case Studies” on page 1–4
- “Heat-Sink Attachment” on page 1–5
- “Device Reworkability” on page 1–8
- “Handling and Transfer” on page 1–10
- “Selecting Heat Sink for Small Heat Source” on page 1–10
- “General Properties of TIM II” on page 1–11
- “Compression During Heat Sink Attachments” on page 1–13
- “Vendors List” on page 1–14

FCmBGA Overview

FCmBGA packages are designed to allow die protrusion over the mold cap. This feature ensures the thinnest bond line and best thermal impedance between the flip chip die and the attached heat sink.

The FCmBGA is produced in an exposed die configuration. This configuration maintains the excellent thermal performance of a bare die flip chip BGA and is enhanced by providing a support surface around the bare die for a direct heat-sink attachment.

Figure 1 and Figure 2 show the package construction and cross-section of the FCmBGA.

Figure 1. Package Construction of an FCmBGA

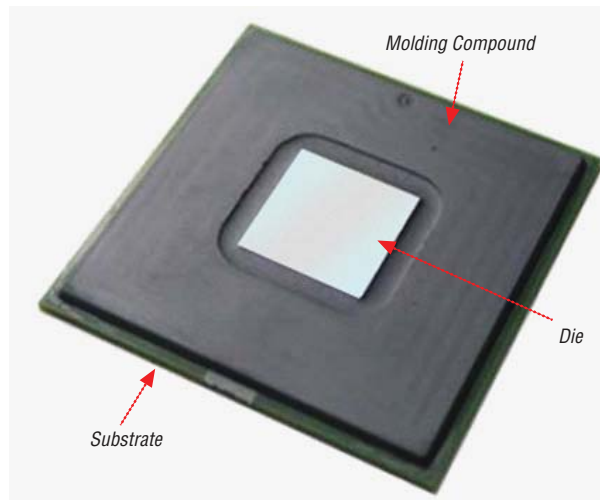
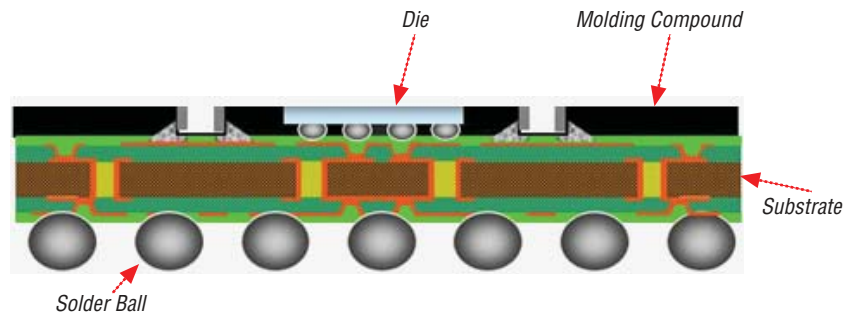

Figure 2. Cross-Sectional View of an FCmBGA Package



Die to Package Profile

To calculate the amount of thermal interface material type II (TIM II) for the heat-sink attachment, you must consider the height of the die above the package body. [Figure 3](#) and [Table 1](#) list the dimensions of the FCmBGA package. For phase change materials (PCMs), thermal conductive tapes, and thermal gap fillers, make sure there is enough TIM II to cover the edge of the die. This practice protects the die edge from chipping or cracking.

Figure 3. Die to Package Profile

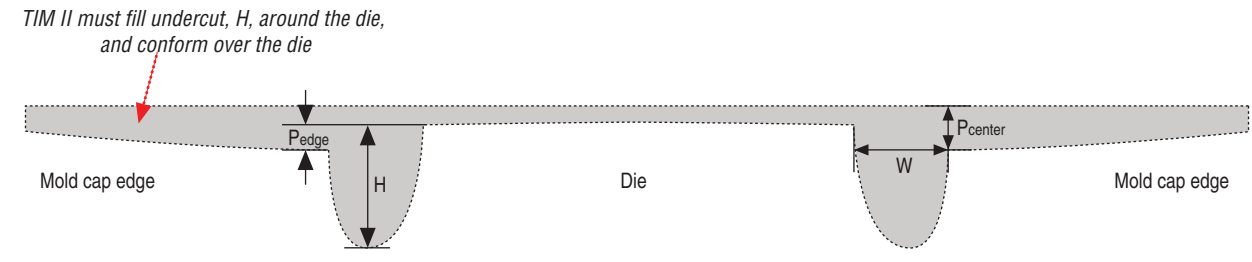

Table 1. Die to Package Dimensions

Parameter	Average	Maximum
P _{edge}	35 μm	43 μm
P _{center}	46 μm	65 μm
H	109 μm	143 μm
W	2.5 mm	2.9 mm

Case Studies

The following sections describe the test cases for different combinations of heat-sink types and TIM IIs.

Simulated Data

This case study was set up to determine the heat sinks and TIM IIs for use with the thermal composite FCmBGA. Altera simulated the thermal tests using the parameters in [Table 2](#).

Table 2. Heat Sink and TIM II Simulation (1), (2)

Parameter	Test Case 1	Test Case 2	Test Case 3	Test Case 4	Test Case 5	Test Case 6	Test Case 7
Heat sink size (mm ²)	40 x 40	40 x 40	40 x 40	40 x 40	40 x 40	40 x 40	50 x 50
Fin count	12	12	12	12	12	12	15
Heat sink type	Non-mechanical attachment	Non-mechanical attachment	Non-mechanical attachment	Mechanical attachment, same body size	Mechanical attachment, same body size	Mechanical attachment, same body size	Mechanical attachment, larger body size
Fastener	Regular	Regular	Regular	Z-clips	Z-clips	Z-clips	Push pins
				Talon clips	Talon clips	Talon clips	Shoulder screw
Power (W)	2	5	10	2	5	10	15
TIM II	Epoxy	Epoxy	Epoxy	PCM	PCM	PCM	PCM
Interface loss (°C)	2.2	5.5	11	0.1	0.4	0.7	1.1
Actual case temp (°C)	63.6	76.5	98.0	61.5	71.3	87.7	81.4
Case/Junction temp target (°C)	85.0	85.0	85.0	85.0	85.0	85.0	85.0
Difference (°C)	21.4	8.5	-13.0	23.5	13.7	-2.7	3.6

Notes to Table 2:

- (1) The case studies were conducted using a 40 mm x 40 mm FCmBGA package with a representative die size of 13 mm x 14 mm, and an air flow of 200 ft/min.
- (2) This study was based on a specific die size and air flow. Different conditions will produce different results. Contact your local Altera® sales office or sales representative for specific application needs.

Simulation Summary

Test cases 1, 2, and 3 use epoxy as TIM II with a non-mechanical heat-sink attachment.

- At 2 W to 5 W, the non-mechanical heat sink with epoxy is sufficient
- As power approaches and exceeds 10 watts, consider a mechanical attachment with heat sinks that are larger than package body size

Test cases 4, 5, and 6 use PCM as TIM II with a mechanical heat-sink attachment.

- At 2 W to 5 W, the mechanical attachment heat sinks with PCM is sufficient
- As power approaches and exceeds 10 watts, consider mechanical attachment with heat sinks that are larger than package body size

Test case 7 uses PCM as TIM II with a mechanical heat-sink attachment.

- The mechanical heat-sink attachment has a body size larger than the FCmBGA package. This setup is sufficient to cool down the device for a high power operation.

Heat-Sink Attachment

There are two types of attachments for heat sinks: mechanical and non-mechanical. [Figure 4](#), [Figure 5](#), and [Figure 6](#) show the different heat-sink attachments.

Figure 4. Non-Mechanical Attachment Type

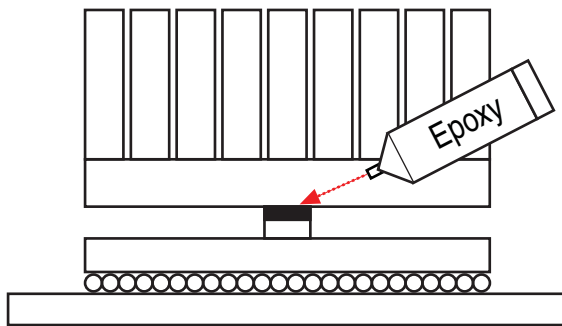

Regular heat sink with epoxy

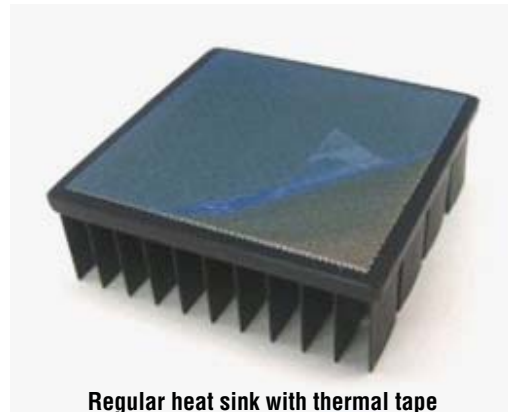

Regular heat sink with thermal tape

Figure 5. Mechanical Attachment Type with Minimum Extra Space

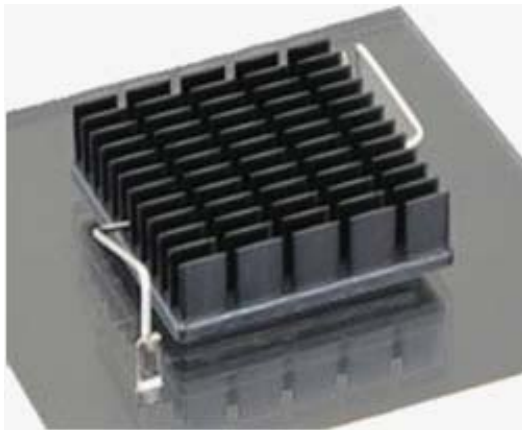

Z-clips

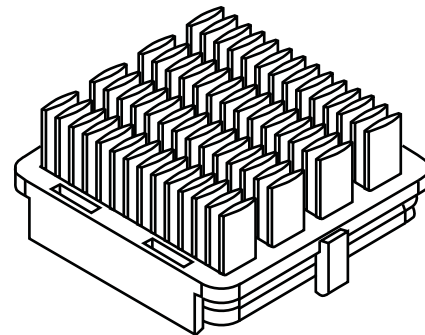

Talon clips

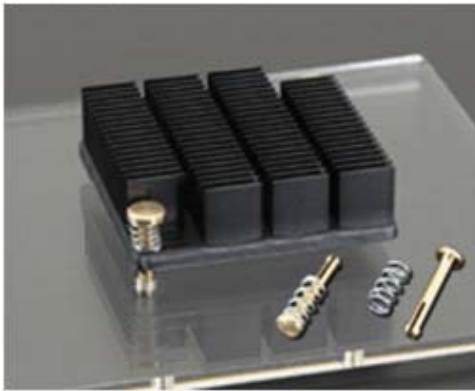
Figure 6. Mechanical Attachment Type with Lock Down Pins**Push pins****Shoulder screws**

Non-mechanical heat-sink attachments are preferred if there are space constraint on the existing boards. There is no additional process of drilling holes on the PCB for locking pins. The TIM II associated with these non-mechanical heat-sink attachments are epoxy or thermal conductive tape. These TIM IIs usually have low conductivity.

Mechanical heat-sink attachments need extra space around the device for push pins or shoulder screws, although Z-clips and talon clips require less extra PCB space. The TIM II associated with these mechanical heat-sink attachments are PCM, thermal grease, and thermal gap filler. The conductivity of these TIM IIs are usually higher than epoxy and thermal conductive tape.

Although the case studies indicated that epoxy thermal performance is similar to PCM, heat sinks with non-mechanical attachments may damage the die. It is also more difficult to control the bond line thickness of epoxy with manual attachment, making it harder to control the thermal performance of the heat sinks.

[Figure 7](#) and [Figure 8](#) show the risk of die damage and poor thermal performance due to uneven heat sink placement for non-mechanical heat-sink attachment.

Figure 7. Die Damage

Figure 8. Uneven Bond Line Thickness of TIM II

With mechanical heat-sink attachments, there is even force on all sides of the heat sink, resulting in an even bond line thickness of the TIM II and even dissipation of heat from the heat sink. [Figure 9](#) shows the even compressive force on the heat-sink mount with mechanical attachment.

Figure 9. Mechanical Heat-Sink Attachment

Device Reworkability

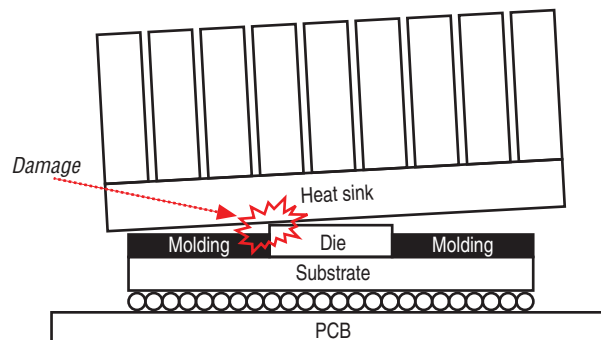
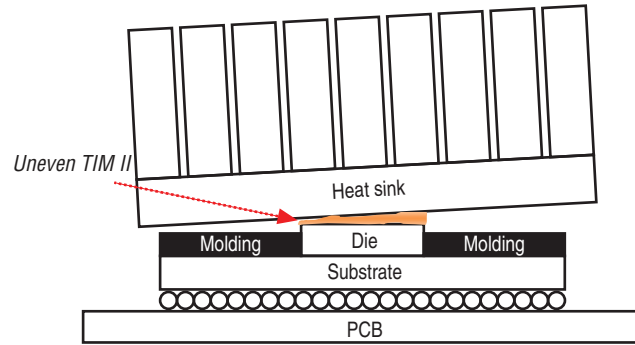
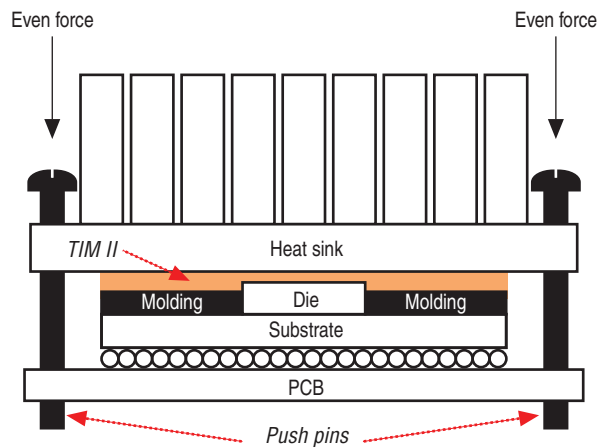
Table 3 summarizes the reworkability of different combinations of heat sinks and TIM IIs.

Table 3. Heat Sink and TIM II Reworkability

Heat Sink Type	TIM II Type	Application	Reworkability
Non-mechanical attachment	Epoxy	Difficult to control the bond line thickness. May not have optimal thermal performance.	High risk of damaging the device or PCB
	Thermal conductive tape	Difficult to conform to the contours of the FCmBGA package, as shown in Figure 3. May not have optimal thermal performance.	High risk of damaging the device or PCB
Mechanical attachment	PCM	Pre-cut to size. Conforms to contour of device	Easy to remove
	Gap filler	Pre-cut to size. Conforms to contour of device. May not have optimal thermal performance	Easy to remove
	Thermal grease	High performance, Conforms to contour of device. Pump-out concerns.	Easy to remove

Rework or Removal of Heat Sinks

To remove a heat sink attached with thermal conductive tape, perform the following steps:

1. Carefully insert the edge of a razor blade between the device and the heat sink. Avoid inserting the entire blade. You only need to create a narrow separation space.
2. Remove the blade and insert the spatula. Twist the spatula slowly to exert upward pressure on the package while moving it inward as the heat sink begins to separate. Avoid touching the die with the metal spatula.
3. To remove the remaining adhesive from the device surface, apply isopropyl alcohol on the remaining adhesive. After few seconds, wipe the adhesive away carefully.
4. Check for damage to the die edge.

Figure 10 shows the removal of the heat sink attached with thermal conductive tape.

Figure 10. thermal Conductive Tape Removal

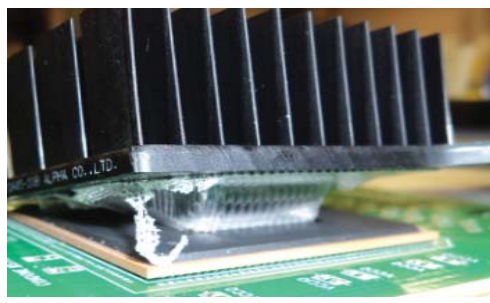
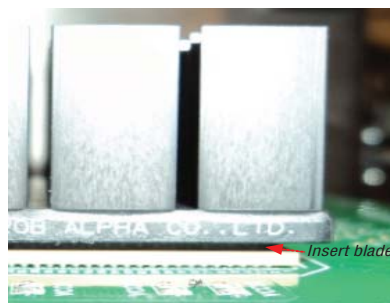

To remove a heat sink attached with epoxy, perform the following steps:

1. Pre-heat unit uniformly in an oven to 115° C – 120° C.
2. Insert the spatula between the heat sink and PCB. Twist the spatula slowly to exert upward pressure. The heat sink will separate from package immediately. Avoid touching the die with the metal spatula.

 Ease of removal is temperature sensitive.

3. Use a sharp single-edge razor blade to carefully remove the cured acrylic from the die area.
4. Allow the device to cool to room temperature before cleaning with isopropyl alcohol.
5. Check for damage to the die edge.

Figure 11 shows the removal of the heat sink attached with epoxy.

Figure 11. Epoxy Removal

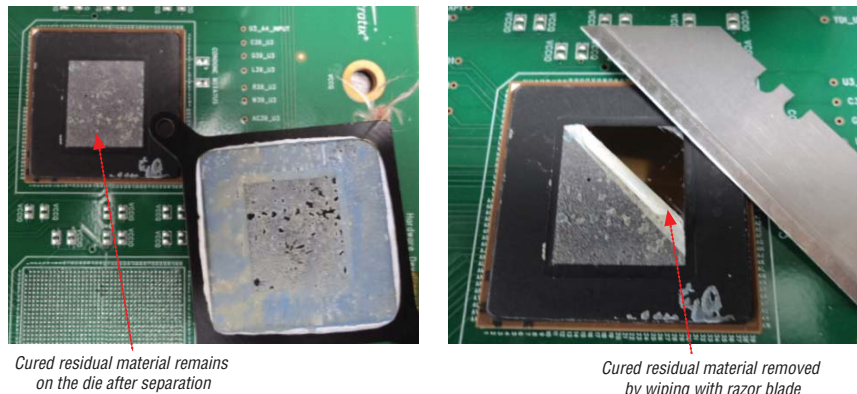

To remove a heat sink attached with PCM or thermal gap filler, perform the following steps:

1. Remove push pins or clips holding the mechanically attached heat sink.
2. Insert a single-edge razor blade into the TIM II bond line between the heat sink and the component.
3. Slowly twist the blade forward with an upward tilt force until the surfaces are separated.
4. Use a sharp single edged razor blade to carefully remove cured PCM from the die area before cleaning with isopropyl alcohol.
5. Check for damage to the die edge.



Do not use a heat gun to remove heat sinks with mechanical or non-mechanical attachments. The high temperature from the heat gun may cause delamination to the underfill of the FCmBGA device, destroying the device in the process.

Handling and Transfer

FCmBGA devices must be handled with great care at all times. They should remain secure in their FCmBGA tray carriers except during transfer operations from tray to tray. You must use the correct FCmBGA trays specified for the size and pin count of the thermal composite FCmBGA. Table 4 lists the FCmBGA tray specifications for the different FCmBGA packages.

Do not use tweezers of any form to pick up the FCmBGA device. Tweezers can cause mechanical damage to the die, whether as scratches to the top of the die or to the bulk silicon in the form of chipped-outs, micro-cracks, or cracks. Altera recommends you manually handle the devices using suitable design tools such as vacuum pencils with rubberized tips for pick-ups.

You must use a soft silicon or rubber tip for automated pick and place machines. The pick and place pressure must be minimized to prevent damage to the die area of the device.

If you must replace the existing solder balls of the device, use the right fixture to prevent the die chipping on the device.

Table 4. FCmBGA Tray Specifications

Package Size (Pin Count)	Tray Part Number
27 mm x 27 mm (F672)	Daewon 125-2727-919
29 mm x 29 mm (F780)	Daewon 1F1-2929-C19
31 mm x 31 mm (F896)	Kostat KS-880120
35 mm x 35 mm (F1152)	Daewon 125-3535-919
40 mm x 40 mm (F1517)	Kostat KS-886H

Selecting Heat Sink for Small Heat Source

It is difficult to cool a smaller heat source because the heat sink's base material resists the spreading of the heat, through the base, to the outer fins. Figure 12 shows an aluminum heat sink with a small heat source.

 Current Altera devices that are small heat sources are the lidless FBGA and the FCmBGA.

Figure 12. Small Heat Source with Aluminum Heat Sink



To spread the heat from a small heat source to the entire base, some heat sink vendors offer efficient and reliable copper embedded heat sinks. [Figure 13](#) shows a copper embedded heat sink. For a list of TIM II, heat sink, and FCmBGA tray vendors, refer to [“Vendors List”](#) on page 1–14.

Figure 13. Small Heat Source with Copper Embedded Heat Sink

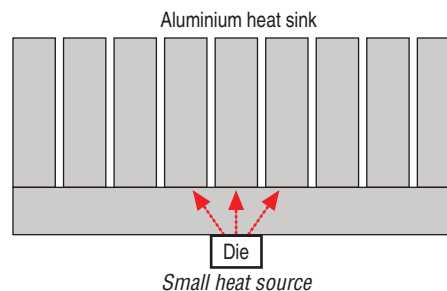
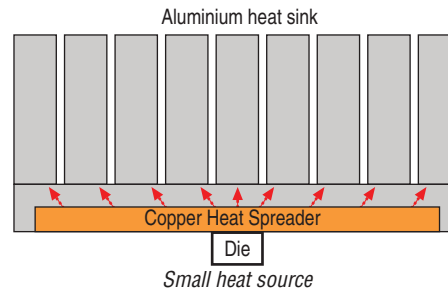

General Properties of TIM II

Altera recommends you consider early in your design what type of suitable TIM II to use. TIM IIs can be the limiting factors in the expense of thermal management designs. You can use TIM II effectively to help reduce the size of the heat sinks and the need for larger cooling fans. The extended benefit of an effective TIM II is a solution that is faster, easier to apply, and less costly than changing heat sinks or redesigning a chassis.

Several material solutions exist that can perform the functions of a TIM II—adhesives, grease, gels, PCMs, and pads. There are advantages and disadvantages associated with each of these TIM II solutions.

Thermal Adhesives or Epoxies

Thermal adhesives are particle-laden, one- or two-component materials that are applied via dispensing or stencil printing. Adhesives are cured to allow for cross-linking of the polymer, which provides the adhesive property. Thermal adhesives are advantageous because they provide structural support, eliminating the need for mechanical clamping.

The disadvantages of using thermal adhesives or epoxies include the following:

- They may not provide sufficient bond strength because of the small contact area
- The relative high impedance will affect the thermal performance significantly
- Device rework is very difficult and may result in damaging the device

Thermal Conductive Tapes

Thermally conductive adhesive tapes are convenient for heat-sink attachments with mid-range thermal performance. They eliminate the need for mechanical clamping.

The disadvantages of using thermal conductive tapes include the following:

- Thermal conductive tape works best on flat surfaces. Plastic ICs are usually concave in the center and heat-sink surfaces may vary. This unevenness can result in air gaps in the interface.
- May not be able to fill up all the gaps because of the contours of the FCmBGA (See [Figure 3 on page 1–3](#)). This can result in air gaps in the interface.
- Device rework is very difficult and may result in damaging the device.
- Heat sinks may come off over time because of the heat and weight of the heat sinks for PCBs that are mounted vertically.

Thermal Grease

Thermal grease contains silicone oils that are loaded with thermally conductive filler. Thermal grease does not require curing and it flows and conforms to surfaces. It also offers a reworkable thermal interface layer. Thermal grease requires mechanical clamping.

A disadvantage of using thermal grease is that it can degrade, pump-out, or dry out during extended operation and over time, causing the thermal performance of the TIM II system using the grease to suffer significantly.

Thermal Gels

Thermal gels are low modulus, paste-like materials that are lightly cross-linked. They perform like grease with respect to their ability to conform to surfaces, while reducing material pump-out. Thermal gels require mechanical clamping.

PCMs

PCMs undergo a transition from a solid to a semi-solid phase with the application of heat and pressure. The material is in a liquid phase at die-operating conditions. PCMs offer several advantages, including the ability to conform to the mating surfaces and no curing is needed. PCMs require mechanical clamping.

Thermal Pads

Thermal pads are fabricated by molding non-reinforced silicone with conductive fillers. Reinforcements for thermal pads can include woven glass, metal foils, and polymer films. Thermal pads are pre-cut and offer gap-filling functionality. They have limited thermal performance and are pressure sensitive. Thermal pads require mechanical clamping.

Compression During Heat Sink Attachments

Most TIM IIs require loads of less than 50 psi to interface the heat sink with the die. Altera recommends the following maximum loads for heat-sink attachments.

During heat sink application, the maximum load should not exceed 20 g/solder ball.

- Failures observed at this load in board bending test; tested on 93 mils thick PCBs result in ~1400 microstrains at the package corner
- May cause solder joints to open

During continuous load, the maximum load should not exceed 4 g/solder ball.

- Solder deformation observed after 2,000 hours of stress; tested for 2,000 hours at 125° C with components in sockets and a back pressure of 10 g to 12 g per solder ball.
- Data extended (assuming linearity in yield strength) to 100,000 hours at 100° C.
- May cause solder ball shorting

Table 5 lists the TIM IIs recommended by Altera TIM II vendors. Typical application recommendations are based on factors such as gap-filling capability, conductivity of materials, compatibility with molding compound, and ease of use.

Table 5. TIM IIs Recommended for the FCmBGA Package ⁽¹⁾

Vendor	Product	Type	Conductivity	Format	Typical Application
Laird Technologies	Tpcm 780	Phase change	5.5 W/m ² K	Pad	Desktop and laptop PCs
Laird Technologies	Tpcm 780SP	Phase change	5.5 W/m ² K	Liquid	Desktop and laptop PCs
Laird Technologies	Tpcm 580	Phase change	3.8 W/m ² K	Pad	CPUs, custom ASIC, GPUs
Laird Technologies	Tgrease 980	Thermal grease	3.8 W/m ² K	Grease	CPUs, custom ASIC, GPUs
Laird Technologies	Tgrease 880	Thermal grease	3.1 W/m ² K	Grease	CPUs, custom ASIC, GPUs
Laird Technologies	Tgrease 2500	Thermal grease	3.8 W/m ² K	Paste	High performance CPUs and GPUs
Bergquist	3500S35	Gap filler (2 parts)	3.6 W/m ² K	Pad	PCBA to housing
Chomerics	T777	Phase change	3.5 W/m ² K	Pad	CPUs, GPUs, chipsets
Chomerics	976	Gap filler	3.0 W/m ² K	Pad	CPUs, GPUs, chipsets
Chomerics	579	Gap filler	1.5 W/m ² K	Pad	CPUs, GPUs, chipsets
Chomerics	T411	Thermal tape	0.5 W/m ² K	Tape	CPUs, GPUs, chipsets
Laird Technologies	T Flex HR600	Gap filler	3.0 W/m ² K	Pad	Cooling to chassis, frames
Laird Technologies	T Flex HR400	Gap filler	1.8 W/m ² K	Pad	Cooling to chassis, frames

Note to Table 5:

- (1) When applying TIM II to heat sink and package, make sure that there is enough TIM II to cover the edges of the die to prevent the die from chipping or cracking.

Vendors List

The following lists contains recommended TIM II vendors:

- Laird Technologies (www.lairdtech.com)
- Chomerics (www.chomerics.com)
- The Bergquist Company (www.bergquistcompany.com)
- 3M (www.3m.com)
- ShinEtsu MicroSi (www.microsi.com)

The following lists contains recommended heat sink vendors:

- Alpha Company (www.alphanovatech.com)
- Malico (www.malico.com.tw)
- Aavid Thermalloy (www.aavidthermalloy.com)
- Radian Heatsinks (www.radianheatsinks.com)

The following lists contains recommended FCmBGA tray vendors:

- Daewon (www.daewonspic.com)
- Kostat (www.kostat.com)

Document Revision History

Table 6 lists the revision history for this document.

Table 6. Document Revision History

Date	Version	Changes
January 2012	1.0	Initial release.