

# DIRECT UP-CONVERSION USING AN FPGA-BASED POLYPHASE MODEM

Rob Pelt  
 Altera Corporation  
 101 Innovation Drive  
 San Jose, California, USA 95134  
[rpelt@altera.com](mailto:rpelt@altera.com)

## 1. ABSTRACT

Performance requirements for broadband modems continue to push the limits of analog technology. Fortunately, today's digital-to-analog converters (DACs) are approaching sampling rates in the gigahertz range. These DACs allow broadband modems to implement multi-channel solutions completely in the digital domain. To fully utilize the available bandwidth of these DACs, new techniques in modem design must be considered. Using polyphase decomposition and sub-sampling, a field programmable gate array (FPGA)-based modem can provide frequency synthesis for the full Nyquist bandwidth of the DAC. This paper describes an FPGA-based modem implementation using these techniques.

## 2. BACKGROUND

Traditionally, frequency translation (i.e., up-conversion) has been performed by analog components. Analog components such as voltage-controlled oscillators (VCOs) and mixers are used to approximate the mathematical expressions of the up-conversion process. Careful design practices must be used to insure the operation of analog components over power, voltage, and temperature. In addition to the normal difficulties involved in analog design, the fact that the analog circuit is only an approximation also introduces unwanted effects in the up-converted signal.

With the current generation of digital signal processors and FPGAs, it is possible to perform some level of frequency translation in the all-digital domain. The fundamental limitation of digital up-conversion is dependent on the clock speed of the digital device. For example, Altera's Stratix<sup>®</sup> II FPGAs have typical internal clock speeds of 300 MHz. Even at this high clock rate, the Nyquist criteria states that the maximum digital bandwidth would be in the range of 150 MHz. Clearly, this is not useable as a direct up-conversion solution.

Currently, modems employ a mixed analog/digital architecture for up-conversion. Figure 1 shows a block diagram of a typical modem using this mixed architecture. In this scheme the FPGA performs the variable up-conversion, while the analog section performs a fixed up-conversion. The remainder of this paper describes a method to eliminate the analog up-conversion section.

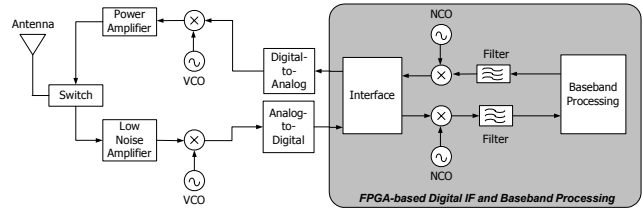

Figure 1. Mixed Analog/Digital Modem

## 3. FPGA OVERVIEW

Before describing the operation of the polyphase modem, an overview of the relevant features of FPGAs is presented. The current generation of FPGAs contains many system-level features. In addition to look-up tables (LUTs) and registers, FPGAs contain: arithmetic operators, phase locked loops (PLL), high-speed I/O pins, and memory. Table 1 shows the features of Altera's Stratix II FPGA family [1] as an example of the rich feature set that can be found in today's advanced FPGAs.

Table 1: Stratix II Family

Device	Equivalent Logic Elements (LEs)	Total Memory Bits	18x18 Multiplier s	PLLs
EP2S15	15,600	419,328	48	6
EP2S30	33,880	1,369,728	64	6
EP2S60	60,440	2,544,192	144	12
EP2S90	90,960	4,520,448	192	12
EP2S130	132,540	6,747,840	252	12
EP2S180	179,400	9,383,040	384	12

## 4. POLYPHASE MODEM

A straightforward implementation of an FPGA-based digital modem will only yield a design with sampling rates of ~300 MHz. Table 2 shows the clock speeds of some common digital modem components that can be implemented in a high-density FPGA.

**Table 2. Common Modem Component Clock Rates**

Component	Maximum Speed
FIR Filter	339 MHz
NCO	404 MHz
FFT (256 point)	314 MHz

With these clock speeds, FPGAs can easily synthesize signals with bandwidths of 150 MHz+.

The current generation of DACs have sampling rates greater than 1 GHz ([2], [3]). FPGAs have low voltage differential signaling (LVDS) interfaces that are capable of supplying signals at the GHz rates needed by the DACs. In order to take advantage of the available bandwidth of these new DACs, traditional FPGA modem design is not sufficient. The following sections look at three (3) ways to achieve these sampling rates.

**4.1. Aliasing Approach**

A traditional method of supplying higher sampling rates is to upsample the signal by means of zero-stuffing. This is an easy, low-overhead method of increasing the sampling frequency. From sampling theory ([4], [5]), it is known that this method of upsampling introduces aliasing. Usually, aliasing is an unwanted by-product; but for our purposes this is actually a benefit. Figure 2 shows the spectrum for an upsampled modem. As seen in this example, the output of the DAC can be bandpass-filtered (using an analog filter) to obtain the desired frequency. This method allows the narrow bandwidth (typically less than 150 MHz) of the FPGA to be translated to any frequency in the Nyquist bandwidth of the DAC (0 to 500 MHz+). Two problems exist when using the upsampling method:

1. The generated signal bandwidth is limited to the Nyquist rate of the FPGA.
2. The analog bandpass filter has a very high center frequency to bandwidth ratio, which makes realization very difficult.

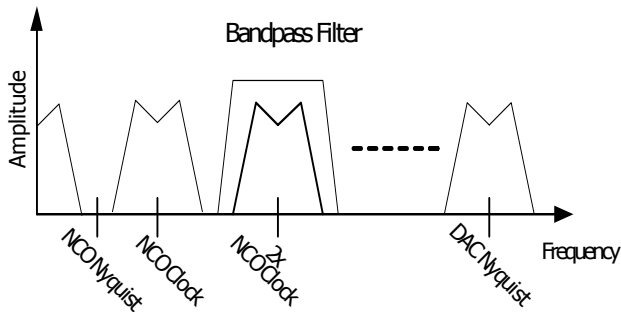

**Figure 2. Upsampled Spectrum**

**4.2. Polyphase Approach**

Another method for generating signals at the DAC sampling rates is to use polyphase decomposition. This is a method commonly used in creating interpolating polyphase FIR filters. Figure 3 shows an example of polyphase decomposition for an FIR filter. The same principle can be applied to the digital upconverter. A polyphase upconverter is shown in Figure 4.

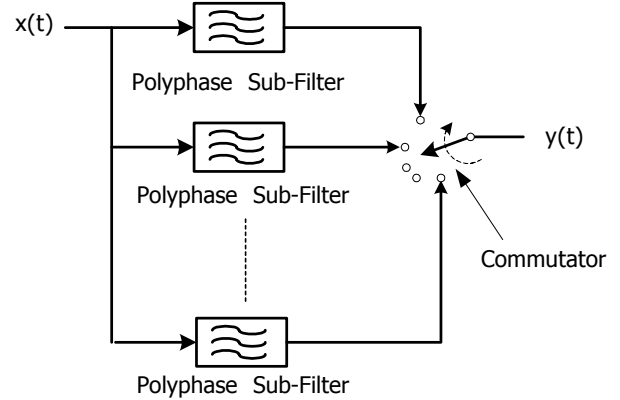

**Figure 3. FIR Polyphase Decomposition**

In Figure 4, each of the *sub-DUC* (a sub-DUC is defined as the polyphase component of the digital up converter) consists of a polyphase sub-filter, a numerically controlled oscillator (NCO) and a mixer. The sub-filters are created using standard filter decomposition [5]. The NCO in each sub-DUC is set to the same frequency, but each has a different initial phase.

The outputs of the sub-DUCs are connected to the input of the LVDS serializer. Similar to the commutator in a polyphase interpolation filter, the serializer runs at N-times the rate of the sub-DUCs. The outputs of the LVDS serializer are connected directly to the high-speed DAC.

The calculation of the initial phase of the sub-DUC NCOs uses the following formula:

$$\phi_N = \frac{360 * F_{gen}}{F_{s\_nco} * N} \quad \text{(Equation 1)}$$

Where:

- N is the number of polyphase (i.e. sub-DUCs)
- $\Phi_N$  is the phase offset on the N<sup>th</sup> NCO in degrees
- $F_{gen}$  is the generated output frequency
- $F_{s\_nco}$  is the sample rate of NCOs

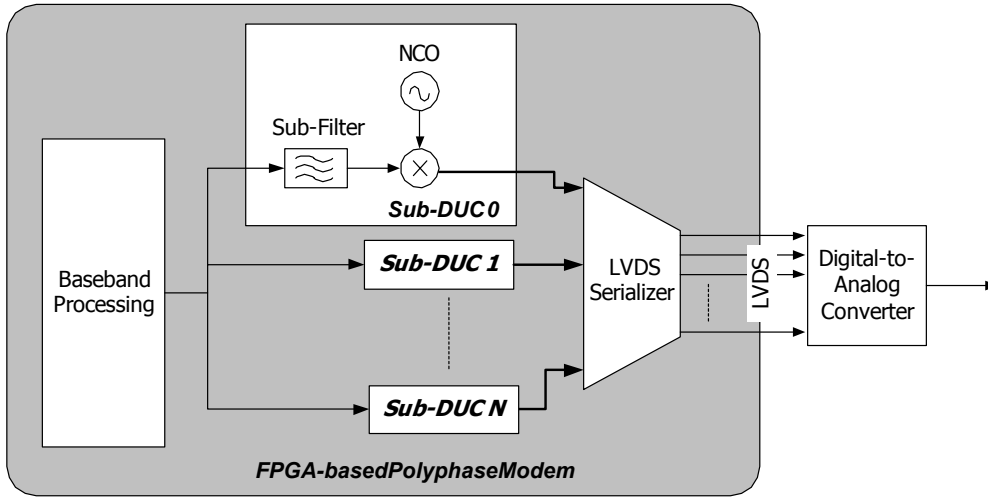

Figure 4. Polyphase Modem

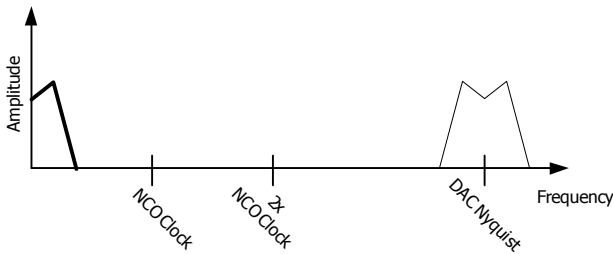

Figure 5. Frequency Spectrum of Polyphase Approach

Figure 5 shows the spectrum resulting from performing up-conversion using the polyphase approach. Notice that there are no aliasing products in the spectrum. This approach, however, limits the output frequency to the Nyquist rate of the sub-DUC.

#### 4.3. Aliasing Polyphase Approach

In order to take advantage of the bandwidth, the polyphase NCO must be capable of generating frequencies up to the Nyquist rate of the DAC. The previous two approaches were limited in both bandwidth and generated frequency. A combination of the previous two approaches results in a design that supports the entire Nyquist bandwidth of the DAC.

The structure of the aliasing polyphase modem is identical to the one shown in Figure . The only difference

is the initial phase of the sub-DUC NCOs. The concept is to create only one alias spectrum at the output of the DAC. This is accomplished by setting the polyphase components (the sub-DUCs) so they have the correct phase offset for the *aliased* spectrum, not the primary spectrum. One caveat is that aliasing causes an inversion of the spectrum. As seen in Figure 4, the spectral inversion only happens for the odd aliases of the spectrum. For this case, the initial phases of the sub-DUC NCOs need to account for this inversion.

To compensate for the spectral inversion of the odd aliases, the following trigonometric identity is used:

$$-\sin(\theta + \phi) = \sin(-\theta - \phi) \quad (\text{Equation 2})$$

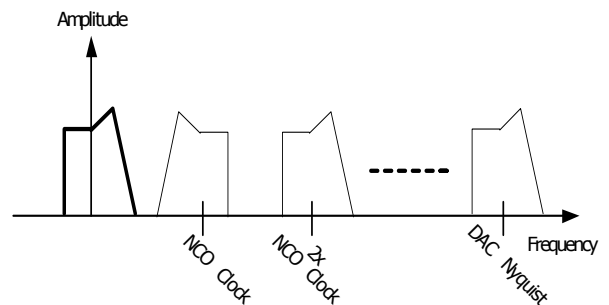

Figure 4. Spectral Inversion Caused by Aliasing

For the initial phase of each NCO, the equation is:

$$\phi_N = \frac{360 * F_{gen}}{F_{s\_dac}} \quad (\text{Equation 3})$$

Where:

- N is the number of sub-DUCs
- $F_{s\_dac}$  is the clock speed of the DAC
- $F_{out}$  is the desired output frequency

To determine the frequency setting of the NCOs, the aliased frequency must be determined by using the following equation:

$$F_{a\_gen} = \begin{cases} F_{gen} & \text{for } F_{gen} < F_{s\_nco}/2 \\ F_{gen} - (F_{s\_nco} * alias) & \text{for } F_{gen} > F_{s\_nco}/2 \end{cases}$$

Where:

- $F_{a\_gen}$  is alias frequency setting for the NCO
- $F_{gen}$  is the desired output frequency
- alias* is the Nyquist zone number

## 5. PERFORMANCE CONSIDERATIONS

The resulting output from the aliased polyphase modem is shown in Figure 5. Notice that the other alias components are present, but are attenuated.

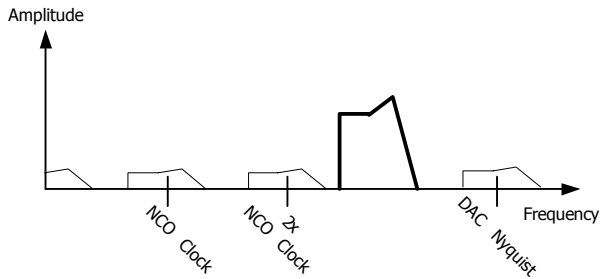

**Figure 5. Aliasing Polyphase Modem Spectrum**

A number of factors affect the attenuation of these components, including:

- NCO output bit width
- NCO accumulator precision
- Number of sub-DUCs used in design
- DAC spurious free dynamic range (SFDR)
- DAC intermodulation distortion

Simulations show that reasonable bit widths (~18-bits) are sufficient to suppress the unwanted alias components by 70 dBc.

## 6. CONCLUSION

The new generation of high-speed DACs has opened up the possibility to create direct digital up-converters.

FPGAs are well-suited for interfacing to these new DACs, but new modem implementations are needed. This paper demonstrated that a direct up-conversion modem can be designed using polyphase techniques along with aliasing. These techniques build on the traditional implementation of FPGA-based modems and multi-rate signal processing.

## 7. REFERENCES

- [1] Altera Corporation, Stratix II Data Sheet, [www.altera.com](http://www.altera.com)
- [2] Analog Devices, AD9736 Data Sheet, [www.analog.com](http://www.analog.com)
- [3] Fujitsu Microelectronics, MB86064 Data Sheet, [www.fujitsu.com](http://www.fujitsu.com)
- [4] Richard Lyons, *Understanding Digital Signal Processing*, Prentice Hall, Copyright 2001
- [5] N.J. Fliege, *Multirate Digital Signal Processing*, John Wiley & Sons, Copyright 1994



101 Innovation Drive  
San Jose, CA 95134  
(408) 544-7000  
[www.altera.com](http://www.altera.com)  
**Applications Hotline:**  
(800) 800-EPLD  
**Literature Services:**  
[literature@altera.com](mailto:literature@altera.com)

Copyright © 2005 Altera Corporation. All rights reserved. Altera, The Programmable Solutions Company, the stylized Altera logo, specific device designations, and all other words and logos that are identified as trademarks and/or service marks are, unless noted otherwise, the trademarks and service marks of Altera Corporation in the U.S. and other countries. All other product or service names are the property of their respective holders. Altera products are protected under numerous U.S. and foreign patents and pending applications, maskwork rights, and copyrights. Altera warrants performance of its semiconductor products to current specifications in accordance with Altera's standard warranty, but reserves the right to make changes to any products and services at any time without notice. Altera assumes no responsibility or liability arising out of the application or use of any information, product, or service described herein except as expressly agreed to in writing by Altera Corporation. Altera customers are advised to obtain the latest version of device specifications before relying on any published information and before placing orders for products or services.

All copyrights reserved.