

Introduction

Cyclone® III family devices (Cyclone III and Cyclone III LS devices) feature embedded memory structures to address the on-chip memory needs of Altera® Cyclone III family devices designs. The embedded memory structure consists of columns of M9K memory blocks that you can configure to provide various memory functions, such as RAM, shift registers, ROM, and FIFO buffers.

This chapter contains the following sections:

- “Memory Modes” on page 3–8
- “Clocking Modes” on page 3–15
- “Design Considerations” on page 3–16

Overview

M9K blocks support the following features:

- 8,192 memory bits per block (9,216 bits per block including parity)
- Independent read-enable (*rden*) and write-enable (*wren*) signals for each port
- Packed mode in which the M9K memory block is split into two 4.5 K single-port RAMs
- Variable port configurations
- Single-port and simple dual-port modes support for all port widths
- True dual-port (one read and one write, two reads, or two writes) operation
- Byte enables for data input masking during writes
- Two clock-enable control signals for each port (port A and port B)
- Initialization file to pre-load memory content in RAM and ROM modes

Table 3-1 summarizes the features supported by the M9K memory

Table 3-1. Summary of M9K Memory Features

Feature	M9K Blocks
Configurations (depth × width)	8192 × 1 4096 × 2 2048 × 4 1024 × 8 1024 × 9 512 × 16 512 × 18 256 × 32 256 × 36
Parity bits	✓
Byte enable	✓
Packed mode	✓
Address clock enable	✓
Single-port mode	✓
Simple dual-port mode	✓
True dual-port mode	✓
Embedded shift register mode (1)	✓
ROM mode	✓
FIFO buffer (1)	✓
Simple dual-port mixed width support	✓
True dual-port mixed width support (2)	✓
Memory initialization file (.mif)	✓
Mixed-clock mode	✓
Power-up condition	Outputs cleared
Register asynchronous clears	Read address registers and output registers only
Latch asynchronous clears	Output latches only
Write or Read operation triggering	Write and Read: Rising clock edges
Same-port read-during-write	Outputs set to “Old Data” or “New Data”
Mixed-port read-during-write	Outputs set to “Old Data” or “Don’t Care”

Notes to Table 3-1:

- (1) FIFO buffers and embedded shift registers that require external logic elements (LEs) for implementing control logic.
 (2) Width modes of ×32 and ×36 are not available.



For information on the number of M9K memory blocks for Cyclone III family devices, refer to the *Cyclone III Device Family Overview* chapter in volume 1 of the *Cyclone III Device Handbook*.

Control Signals

The clock-enable control signal controls the clock entering the input and output registers, and the entire M9K memory block as well. This signal disables the clock so that the M9K memory block does not see any clock edges and does not perform any operations.

The `rden` and `wren` control signals control the read and write operations for each port of M9K memory blocks. You can disable `rden` or `wren` signals independently to save power whenever the operation is not required.

Figure 3-1 shows how the register clock, clear, and control signals are implemented in Cyclone III family devices M9K memory block.

Figure 3-1. M9K Control Signal Selection

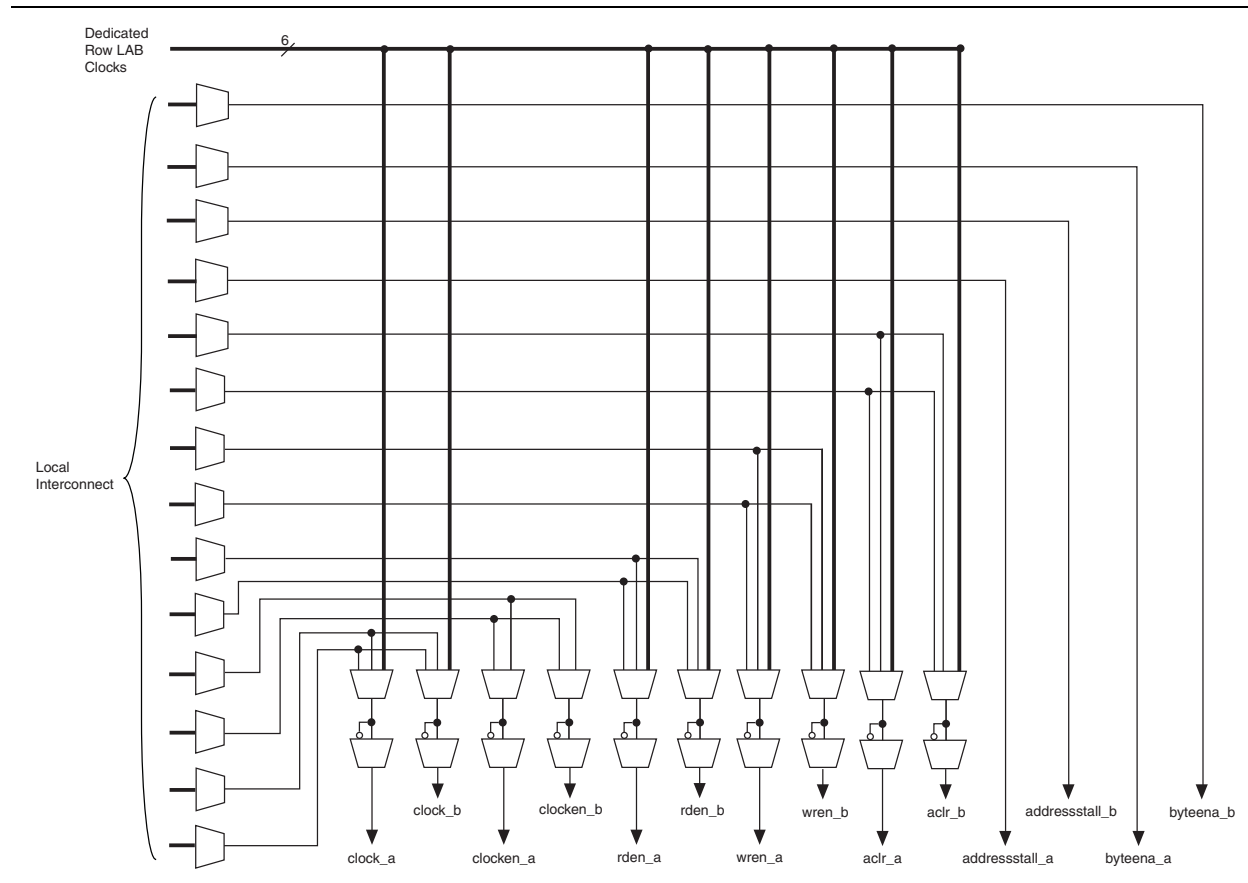

Parity Bit Support

Parity checking for error detection is possible with the parity bit along with internal logic resources. Cyclone III family devices M9K memory blocks support a parity bit for each storage byte. You can use this bit optionally as a parity bit, or as an additional data bit. No parity function is actually performed on this bit.

Byte Enable Support

Cyclone III family devices M9K memory blocks support byte enables that mask the input data so that only specific bytes of data are written. The unwritten bytes retain the previous written value. The `wren` signals, along with the byte-enable (`byteena`) signals, control the write operations of the RAM block. The default value of the `byteena` signals is high (enabled), in which case writing is controlled only by the `wren` signals. There is no clear port to the `byteena` registers. M9K blocks support byte enables when the write port has a data width of $\times 16$, $\times 18$, $\times 32$, or $\times 36$ bits.

Byte enables operate in one-hot manner, with the LSB of the `byteena` signal corresponding to the least significant byte of the data bus. For example, if `byteena = 01` and you are using a RAM block in $\times 18$ mode, `data [8..0]` is enabled and `data [17..9]` is disabled. Similarly, if `byteena = 11`, both `data [8..0]` and `data [17..9]` are enabled. Byte enables are active high.

Table 3-2 summarizes the byte selection.

Table 3-2. `byteena` for Cyclone III Family Devices M9K Blocks (Note 1)

<code>byteena[3..0]</code>	Affected Bytes			
	<code>datain \times 16</code>	<code>datain \times 18</code>	<code>datain \times 32</code>	<code>datain \times 36</code>
[0] = 1	[7..0]	[8..0]	[7..0]	[8..0]
[1] = 1	[15..8]	[17..9]	[15..8]	[17..9]
[2] = 1	—	—	[23..16]	[26..18]
[3] = 1	—	—	[31..24]	[35..27]

Note to Table 3-2:

(1) Any combination of byte enables is possible.

Figure 3-2 shows how the `wren` and `byteena` signals control the operations of the RAM.

Figure 3-2. Cyclone III Family Devices `byteena` Functional Waveform (Note 1)

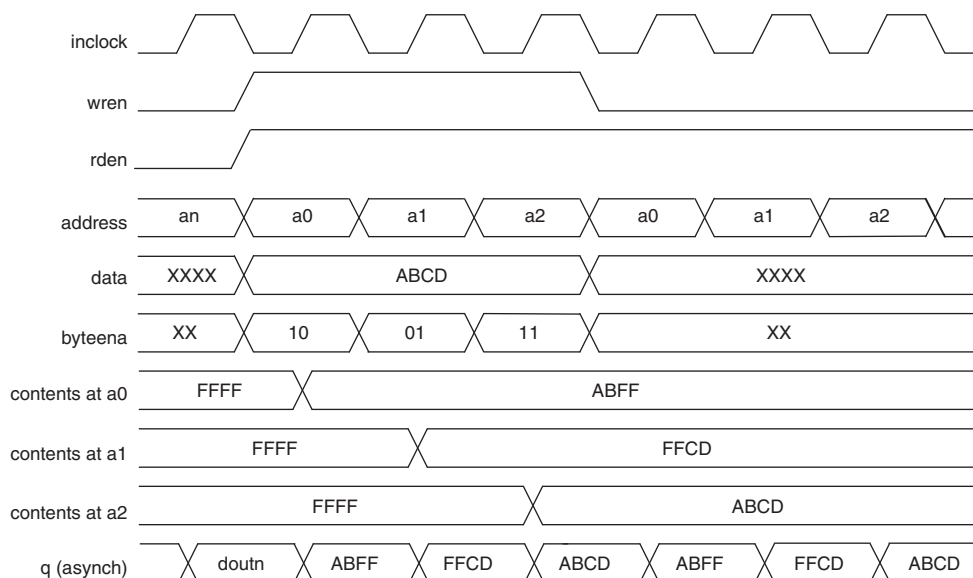

Note to Figure 3-2:

(1) For this functional waveform, “New Data” mode is selected.

When a `byteena` bit is deasserted during a write cycle, the old data in the memory appears in the corresponding data-byte output. When a `byteena` bit is asserted during a write cycle, the corresponding data-byte output depends on the setting chosen in the Quartus® II software. The setting can either be the newly written data or the old data at that location.

Packed Mode Support

Cyclone III family devices M9K memory blocks support packed mode. You can implement two single-port memory blocks in a single block under the following conditions:

- Each of the two independent block sizes is less than or equal to half of the M9K block size. The maximum data width for each independent block is 18 bits wide.
- Each of the single-port memory blocks is configured in single-clock mode. For more information on packed mode support, refer to “Single-Port Mode” on page 3-8 and “Single-Clock Mode” on page 3-16.

Address Clock Enable Support

Cyclone III family devices M9K memory blocks support an active-low address clock enable, which holds the previous address value for as long as the `addressstall` signal is high (`addressstall = '1'`). When you configure M9K memory blocks in dual-port mode, each port has its own independent address clock enable.

Figure 3-3 shows an address clock enable block diagram. The address register output feeds back to its input via a multiplexer. The multiplexer output is selected by the address clock enable (`addressstall`) signal.

Figure 3-3. Cyclone III Family Devices Address Clock Enable Block Diagram

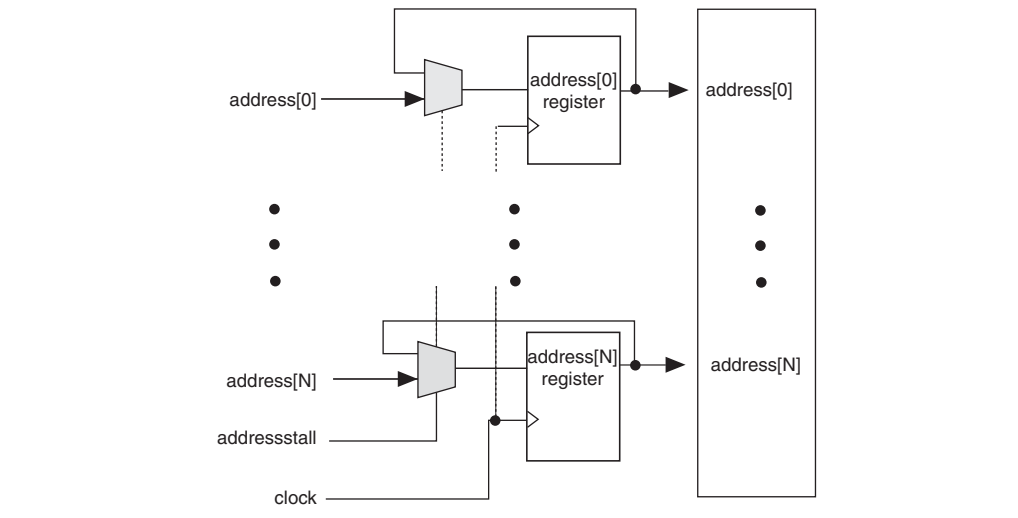

The address clock enable is typically used to improve the effectiveness of cache memory applications during a cache-miss. The default value for the address clock enable signals is low.

Figure 3-4 and Figure 3-5 show the address clock enable waveforms during read and write cycles, respectively.

Figure 3-4. Cyclone III Family Devices Address Clock Enable During Read Cycle Waveform

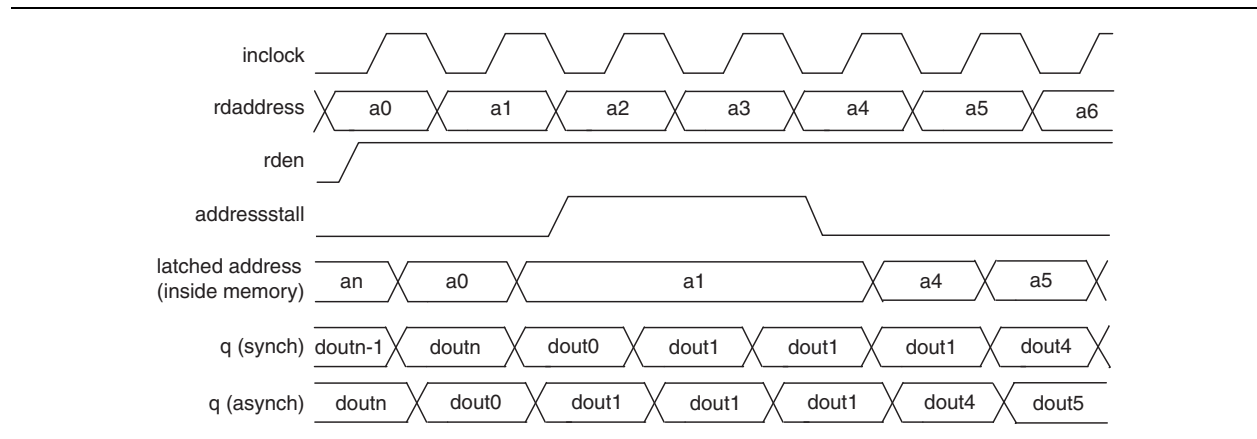
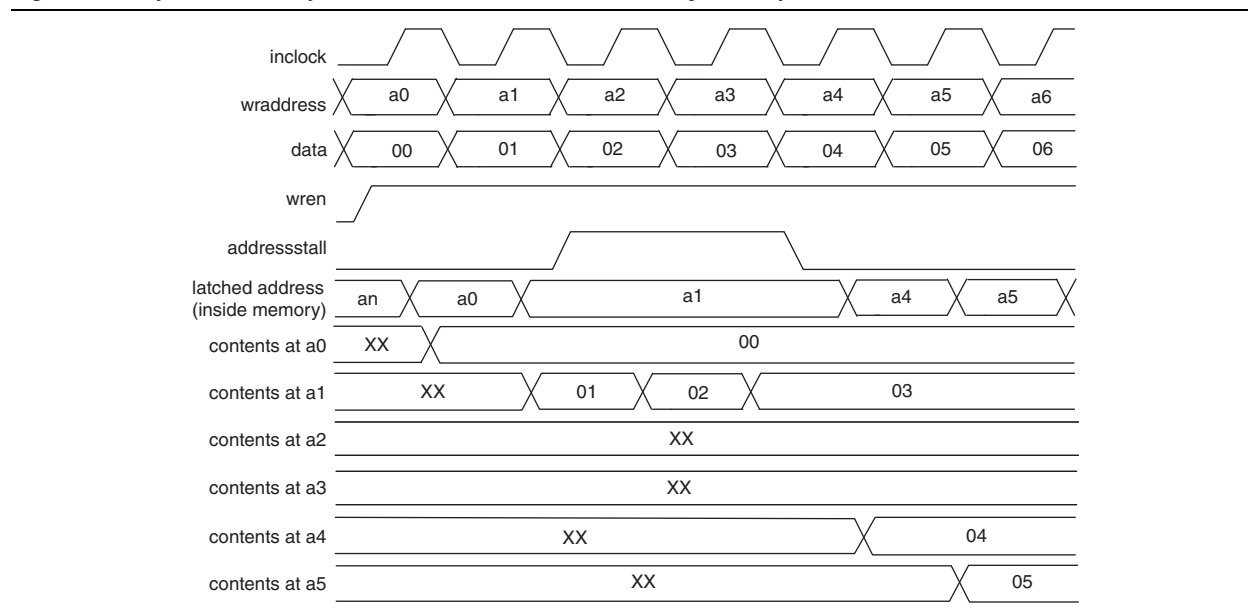

Figure 3-5. Cyclone III Family Devices Address Clock Enable During Write Cycle Waveform



Mixed-Width Support

M9K memory blocks support mixed data widths. When using simple dual-port, true dual-port, or FIFO modes, mixed width support allows you to read and write different data widths to an M9K memory block. For details on the different widths supported per memory mode, refer to “[Memory Modes](#)” on page 3-8.

Asynchronous Clear

Cyclone III family devices support asynchronous clears for read address registers, output registers, and output latches only. Input registers other than read address registers are not supported. When applied to output registers, the asynchronous clear signal clears the output registers, and the effects are immediately seen. If your RAM does not use the output registers, you can still clear the RAM outputs via the output latch asynchronous clear.



 Asserting asynchronous clear to the read address register during a read operation might corrupt the memory content.

Figure 3-6 shows the functional waveform for the asynchronous clear feature.

Figure 3-6. Output Latch Asynchronous Clear Waveform

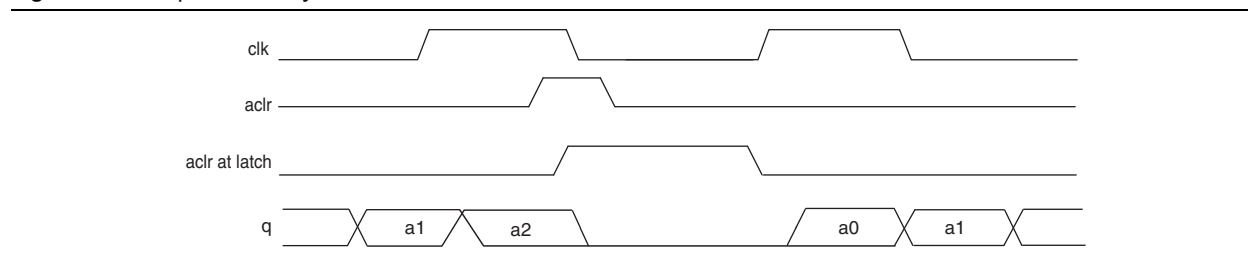

 You can selectively enable asynchronous clears per logical memory via the Quartus II RAM MegaWizard™ Plug-In Manager.

 For more information, refer to the *RAM Megafunction User Guide*.

There are three ways to reset registers in the M9K blocks:

- Power up the device
- Use the `aclr` signal for output register only
- Assert the device-wide reset signal using the `DEV_CLRn` option

Memory Modes

Cyclone III family devices M9K memory blocks allow you to implement fully-synchronous SRAM memory in multiple modes of operation. Cyclone III family devices M9K memory blocks do not support asynchronous (unregistered) memory inputs.

M9K memory blocks support the following modes:

- Single-port
- Simple dual-port
- True dual-port
- Shift-register
- ROM
- FIFO

 Violating the setup or hold time on the M9K memory block input registers might corrupt memory contents. This applies to both read and write operations.

Single-Port Mode

Single-port mode supports non-simultaneous read and write operations from a single address. [Figure 3-7](#) shows the single-port memory configuration for Cyclone III family devices M9K memory blocks.

Figure 3-7. Single-Port Memory (*Note 1*), (*2*)

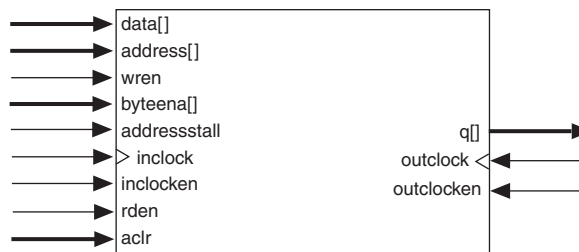

Notes to Figure 3-7:

- (1) You can implement two single-port memory blocks in a single M9K block.
- (2) For more details, refer to “[Packed Mode Support](#)” on page 3-5.

During a write operation, the behavior of the RAM outputs is configurable. If you activate `rden` during a write operation, the RAM outputs show either the new data being written or the old data at that address. If you perform a write operation with `rden` deactivated, the RAM outputs retain the values they held during the most recent active `rden`.

To choose the desired behavior, set the **Read-During-Write** option to either “New Data” or “Old Data” in the RAM MegaWizard Plug-In Manager in the Quartus II software. For more information on read-during-write mode, refer to [“Read-During-Write Operations” on page 3-16](#).

The port width configurations for M9K blocks in single-port mode are as follow:

- 8192 × 1
- 4096 × 2
- 2048 × 4
- 1024 × 8
- 1024 × 9
- 512 × 16
- 512 × 18
- 256 × 32
- 256 × 36

Figure 3-8 shows timing waveforms for read and write operations in single-port mode with unregistered outputs. Registering the outputs of the RAM would simply delay the `q` output by one clock cycle.

Figure 3-8. Cyclone III Family Devices Single-Port Mode Timing Waveforms

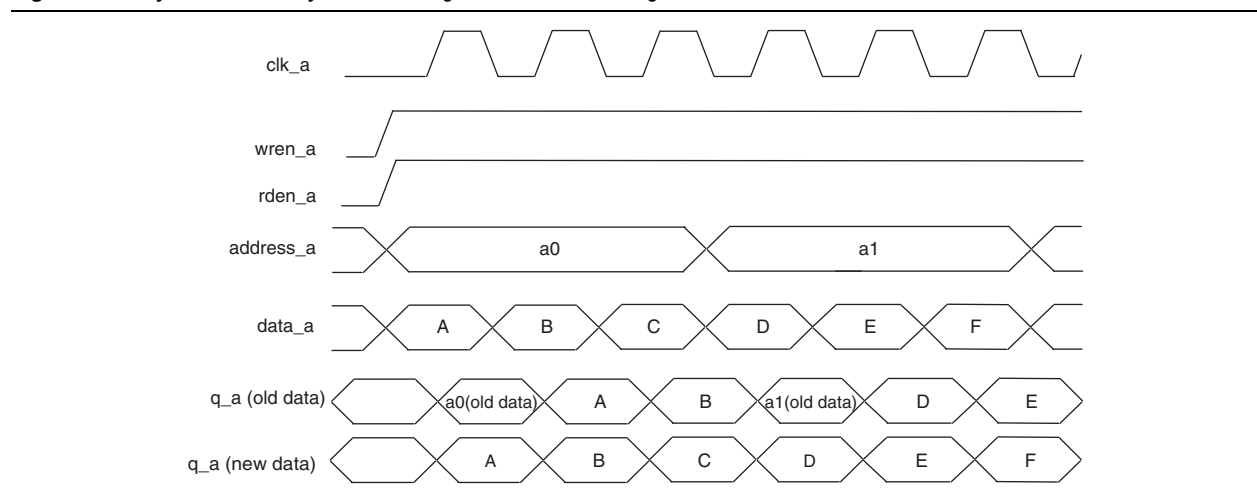

Simple Dual-Port Mode

Simple dual-port mode supports simultaneous read and write operation to different locations.

Figure 3-9 shows the simple dual-port memory configuration.

Figure 3-9. Cyclone III Family Devices Simple Dual-Port Memory (Note 1)

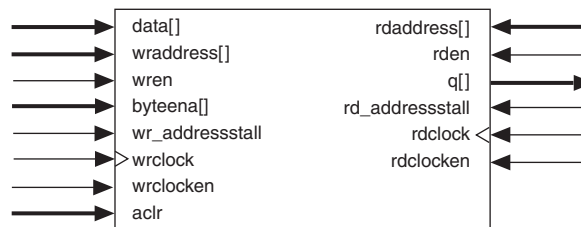

Note to Figure 3-9:

(1) Simple dual-port RAM supports input or output clock mode in addition to the read or write clock mode shown.

Cyclone III family devices M9K memory blocks support mixed-width configurations, allowing different read and write port widths.

Table 3-3 shows mixed-width configurations.

Table 3-3. Cyclone III Family Devices M9K Block Mixed-Width Configurations (Simple Dual-Port Mode)

Read Port	Write Port								
	8192 × 1	4096 × 2	2048 × 4	1024 × 8	512 × 16	256 × 32	1024 × 9	512 × 18	256 × 36
8192 × 1	✓	✓	✓	✓	✓	✓	—	—	—
4096 × 2	✓	✓	✓	✓	✓	✓	—	—	—
2048 × 4	✓	✓	✓	✓	✓	✓	—	—	—
1024 × 8	✓	✓	✓	✓	✓	✓	—	—	—
512 × 16	✓	✓	✓	✓	✓	✓	—	—	—
256 × 32	✓	✓	✓	✓	✓	✓	—	—	—
1024 × 9	—	—	—	—	—	—	✓	✓	✓
512 × 18	—	—	—	—	—	—	✓	✓	✓
256 × 36	—	—	—	—	—	—	✓	✓	✓

In simple dual-port mode, M9K memory blocks support separate `wren` and `rden` signals. You can save power by keeping the `rden` signal low (inactive) when not reading. Read-during-write operations to the same address can either output “Don’t Care” data at that location or output “Old Data”. To choose the desired behavior, set the **Read-During-Write** option to either “Don’t Care” or “Old Data” in the RAM MegaWizard Plug-In Manager in the Quartus II software. For more information on this behavior, refer to [“Read-During-Write Operations” on page 3-16](#).

Figure 3-10 shows the timing waveforms for read and write operations in simple dual-port mode with unregistered outputs. Registering the outputs of the RAM would simply delay the *q* output by one clock cycle.

Figure 3-10. Cyclone III Family Devices Simple Dual-Port Timing Waveforms

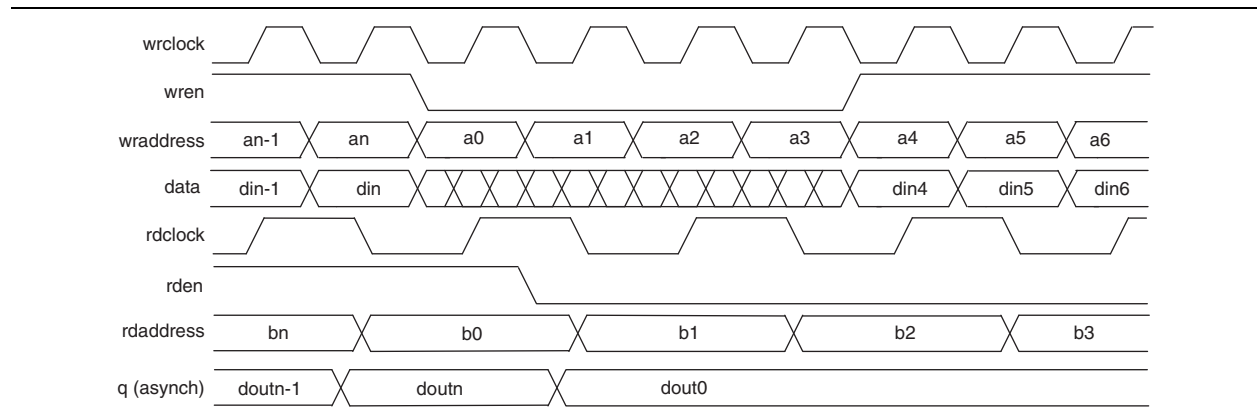

True Dual-Port Mode

True dual-port mode supports any combination of two-port operations: two reads, two writes, or one read and one write, at two different clock frequencies.

Figure 3-11 shows Cyclone III family devices true dual-port memory configuration.

Figure 3-11. Cyclone III Family Devices True Dual-Port Memory (Note 1)

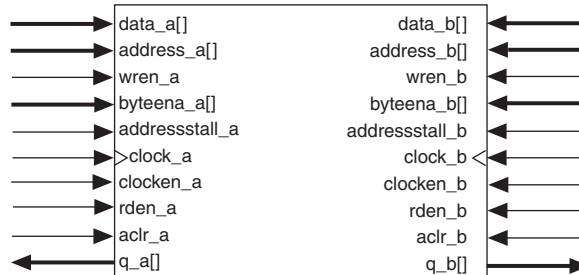

Note to Figure 3-11:

(1) True dual-port memory supports input or output clock mode in addition to the independent clock mode shown.



The widest bit configuration of the M9K blocks in true dual-port mode is 512 × 16-bit (18-bit with parity).

Table 3-4 lists the possible M9K block mixed-port width configurations.

Table 3-4. Cyclone III Family Devices M9K Block Mixed-Width Configurations (True Dual-Port Mode)

Read Port	Write Port						
	8192 × 1	4096 × 2	2048 × 4	1024 × 8	512 × 16	1024 × 9	512 × 18
8192 × 1	✓	✓	✓	✓	✓	—	—
4096 × 2	✓	✓	✓	✓	✓	—	—
2048 × 4	✓	✓	✓	✓	✓	—	—
1024 × 8	✓	✓	✓	✓	✓	—	—
512 × 16	✓	✓	✓	✓	✓	—	—
1024 × 9	—	—	—	—	—	✓	✓
512 × 18	—	—	—	—	—	✓	✓

In true dual-port mode, M9K memory blocks support separate *wren* and *rden* signals. You can save power by keeping the *rden* signal low (inactive) when not reading. Read-during-write operations to the same address can either output “New Data” at that location or “Old Data”. To choose the desired behavior, set the **Read-During-Write** option to either “New Data” or “Old Data” in the RAM MegaWizard Plug-In Manager in the Quartus II software. For more information on this behavior, refer to [“Read-During-Write Operations” on page 3-16](#).

In true dual-port mode, you can access any memory location at any time from either port A or port B. However, when accessing the same memory location from both ports, you must avoid possible write conflicts. When you attempt to write to the same address location from both ports at the same time, a write conflict happens. This results in unknown data being stored to that address location. There is no conflict resolution circuitry built into the Cyclone III family devices M9K memory blocks. You must handle address conflicts external to the RAM block.

Figure 3-12 shows true dual-port timing waveforms for the write operation at port A and read operation at port B. Registering the outputs of the RAM simply delays the *q* outputs by one clock cycle.

Figure 3-12. Cyclone III Family Devices True Dual-Port Timing Waveforms

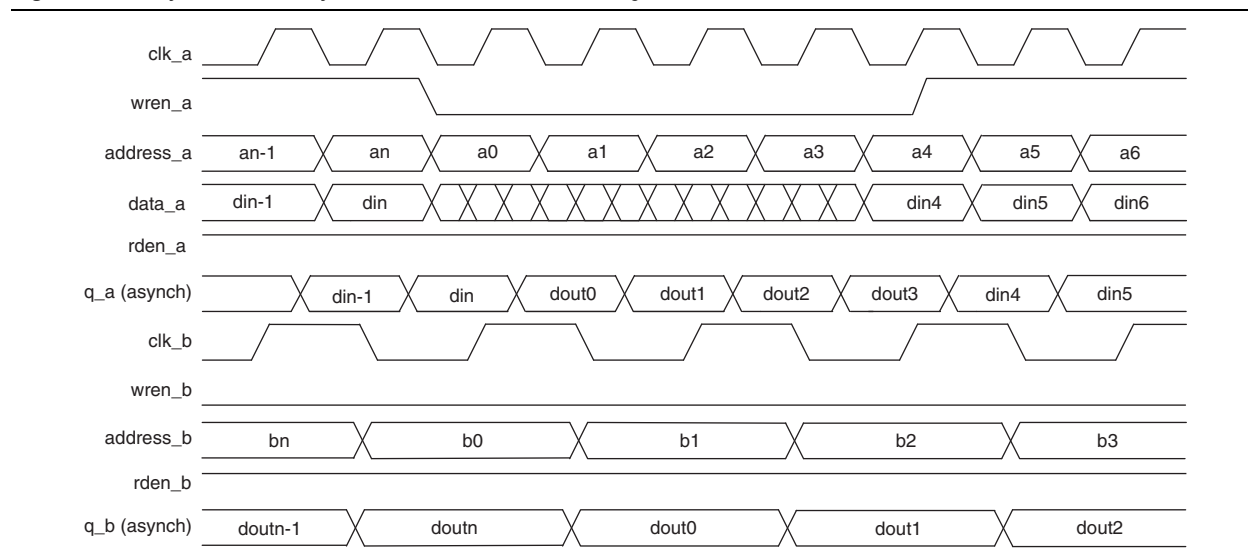

Shift Register Mode

Cyclone III family devices M9K memory blocks can implement shift registers for digital signal processing (DSP) applications, such as finite impulse response (FIR) filters, pseudo-random number generators, multi-channel filtering, and auto-correlation and cross-correlation functions. These and other DSP applications require local data storage, traditionally implemented with standard flip-flops that quickly exhaust many logic cells for large shift registers. A more efficient alternative is to use embedded memory as a shift register block, which saves logic cell and routing resources.

The size of a ($w \times m \times n$) shift register is determined by the input data width (w), the length of the taps (m), and the number of taps (n), and must be less than or equal to the maximum number of memory bits, which is 9,216 bits. In addition, the size of ($w \times n$) must be less than or equal to the maximum width of the block, which is 36 bits. If a larger shift register is required, you can cascade the M9K memory blocks.

Figure 3-13 shows the Cyclone III family devices M9K memory block in the shift register mode.

Figure 3-13. Cyclone III Family Devices Shift Register Mode Configuration

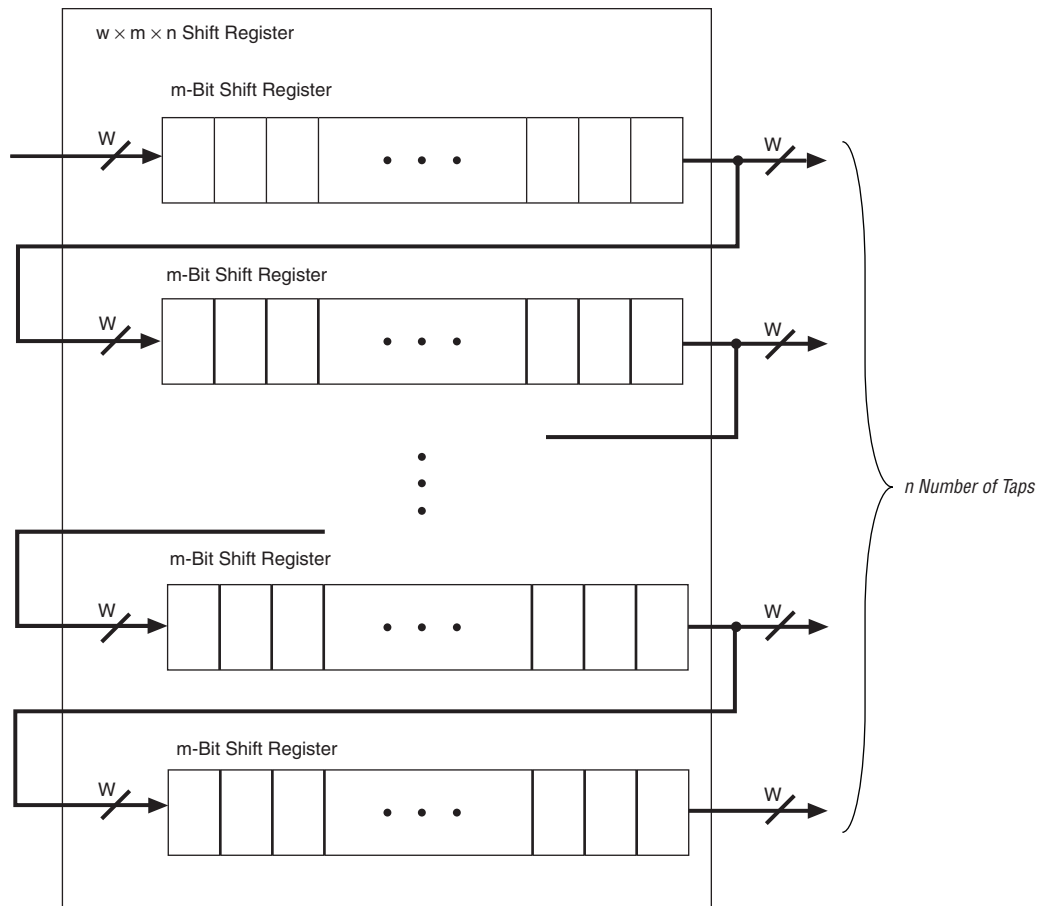

ROM Mode

Cyclone III family devices M9K memory blocks support ROM mode. A `.mif` initializes the ROM contents of these blocks. The address lines of the ROM are registered. The outputs can be registered or unregistered. The ROM read operation is identical to the read operation in the single-port RAM configuration.

FIFO Buffer Mode

Cyclone III family devices M9K memory blocks support single-clock or dual-clock FIFO buffers. Dual clock FIFO buffers are useful when transferring data from one clock domain to another clock domain. Cyclone III family devices M9K memory blocks do not support simultaneous read and write from an empty FIFO buffer.



For more information on FIFO buffers, refer to the [Single- and Dual-Clock FIFO Megafunction User Guide](#).

Clocking Modes

Cyclone III family devices M9K memory blocks support the following clocking modes:

- Independent
- Input or output
- Read or write
- Single-clock

When using read or write clock mode, if you perform a simultaneous read or write to the same address location, the output read data is unknown. If you require the output data to be a known value in this case, use either single-clock mode or I/O clock mode, and choose the appropriate read-during-write behavior in the MegaWizard Plug-In Manager.

 Violating the setup or hold time on the memory block input registers might corrupt the memory contents. This applies to both read and write operations.

 Asynchronous clears are available on read address registers, output registers, and output latches only.

Table 3-5 shows the clocking mode versus memory mode support matrix.

Table 3-5. Cyclone III Family Devices Memory Clock Modes

Clocking Mode	True Dual-Port Mode	Simple Dual-Port Mode	Single-Port Mode	ROM Mode	FIFO Mode
Independent	✓	—	—	✓	—
Input or output	✓	✓	✓	✓	—
Read or write	—	✓	—	—	✓
Single-clock	✓	✓	✓	✓	✓

Independent Clock Mode

Cyclone III family devices M9K memory blocks can implement independent clock mode for true dual-port memories. In this mode, a separate clock is available for each port (port A and port B). `clock_A` controls all registers on the port A side, while `clock_B` controls all registers on the port B side. Each port also supports independent clock enables for port A and B registers.

I/O Clock Mode

Cyclone III family devices M9K memory blocks can implement input or output clock mode for FIFO, single-port, true, and simple dual-port memories. In this mode, an input clock controls all input registers to the memory block including data, address, `byteena`, `wren`, and `rden` registers. An output clock controls the data-output registers. Each memory block port also supports independent clock enables for input and output registers.

Read or Write Clock Mode

Cyclone III family devices M9K memory blocks can implement read or write clock mode for FIFO and simple dual-port memories. In this mode, a write clock controls the data inputs, write address, and `wren` registers. Similarly, a read clock controls the data outputs, read address, and `rden` registers. M9K memory blocks support independent clock enables for both the read and write clocks.

When using read or write mode, if you perform a simultaneous read or write to the same address location, the output read data is unknown. If you require the output data to be a known value, use either single-clock mode, input clock mode, or output clock mode and choose the appropriate read-during-write behavior in the MegaWizard Plug-In Manager.

Single-Clock Mode

Cyclone III family devices M9K memory blocks can implement single-clock mode for FIFO, ROM, true dual-port, simple dual-port, and single-port memories. In this mode, you can control all registers of the M9K memory block with a single clock together with clock enable.

Design Considerations

This section describes the guidelines for designing with M9K memory blocks.

Read-During-Write Operations

“Same-Port Read-During-Write Mode” on page 3-17 and “Mixed-Port Read-During-Write Mode” on page 3-18 describe the functionality of the various RAM configurations when reading from an address during a write operation at that same address.

There are two read-during-write data flows: same-port and mixed-port.

Figure 3-14 shows the difference between these flows.

Figure 3-14. Cyclone III Family Devices Read-During-Write Data Flow

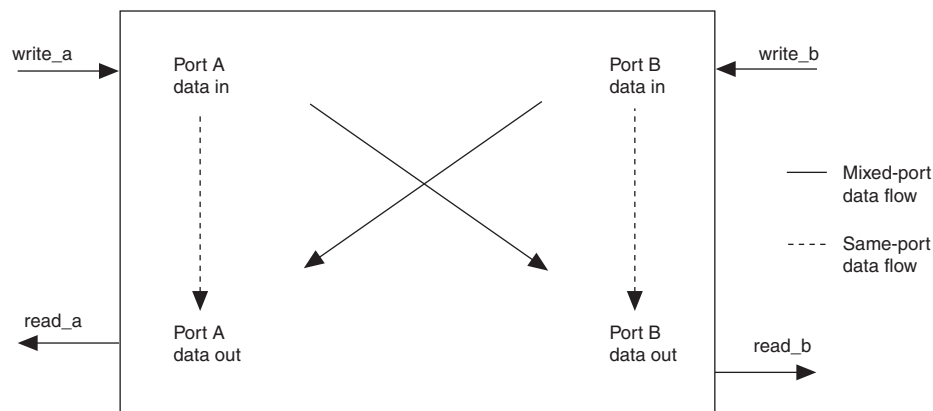

Same-Port Read-During-Write Mode

This mode applies to a single-port RAM or the same port of a true dual-port RAM. In the same port read-during-write mode, there are two output choices: “New Data” mode (or flow-through) and “Old Data” mode. In the “New Data” mode, new data is available on the rising edge of the same clock cycle on which it was written. In “Old Data” mode, the RAM outputs reflect the old data at that address before the write operation proceeds.

When using “New Data” mode together with `byteena`, you can control the output of the RAM. When `byteena` is high, the data written into the memory passes to the output (flow-through). When `byteena` is low, the masked-off data is not written into the memory and the old data in the memory appears on the outputs. Therefore, the output can be a combination of new and old data determined by `byteena`.

Figure 3-15 and Figure 3-16 show sample functional waveforms of same port read-during-write behavior with both “New Data” and “Old Data” modes, respectively.

Figure 3-15. Same Port Read-During Write: New Data Mode

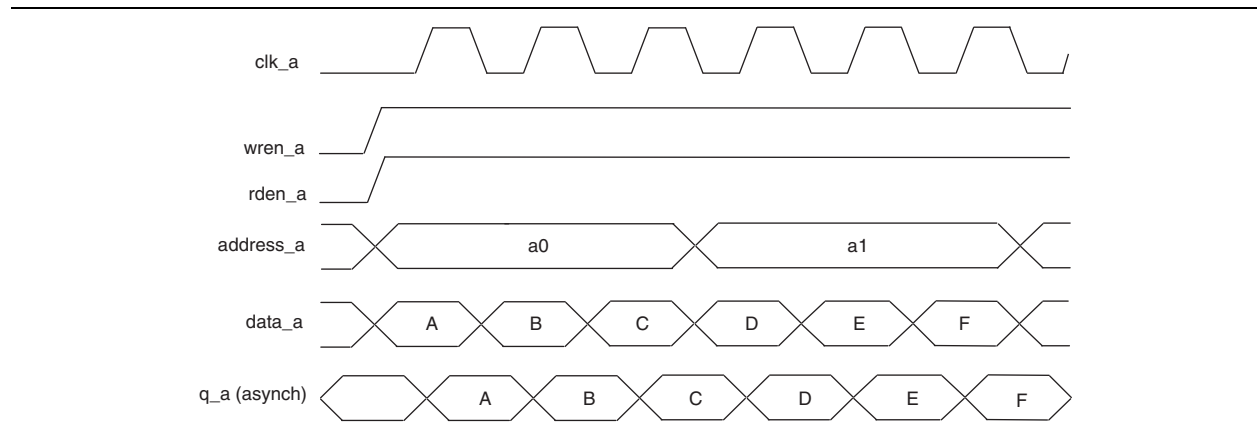
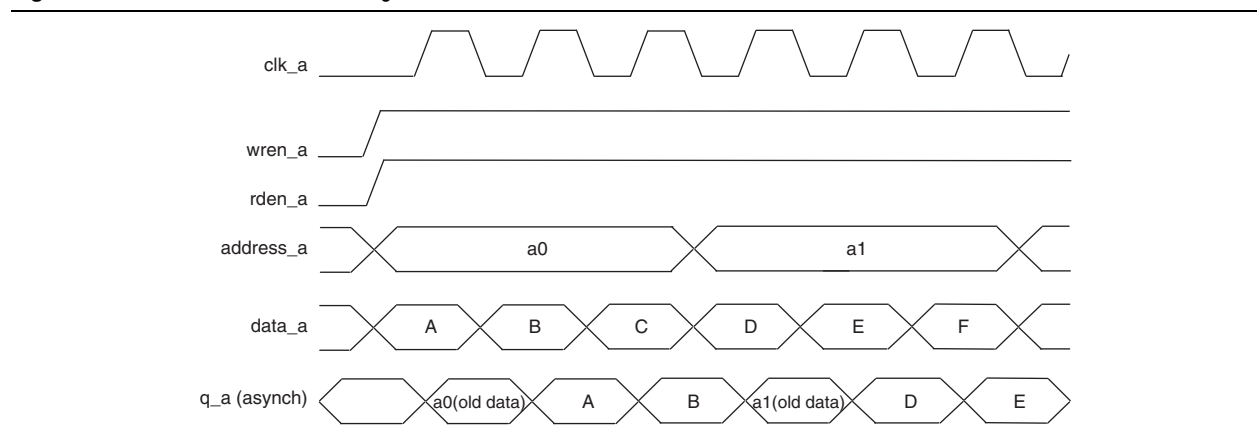

Figure 3-16. Same Port Read-During-Write: Old Data Mode



Mixed-Port Read-During-Write Mode

This mode applies to a RAM in simple or true dual-port mode, which has one port reading and the other port writing to the same address location with the same clock.

In this mode, you also have two output choices: “Old Data” or “Don't Care”. In “Old Data” mode, a read-during-write operation to different ports causes the RAM outputs to reflect the old data at that address location. In “Don't Care” mode, the same operation results in a “Don't Care” or unknown value on the RAM outputs.



 For more information on how to implement the desired behavior, refer to the [RAM Megafunction User Guide](#).

Figure 3-17 shows a sample functional waveform of mixed port read-during-write behavior for the “Old Data” mode. In “Don't Care” mode, the old data shown in the figure is simply replaced with “Don't Care”.

Figure 3-17. Mixed Port Read-During-Write: Old Data Mode

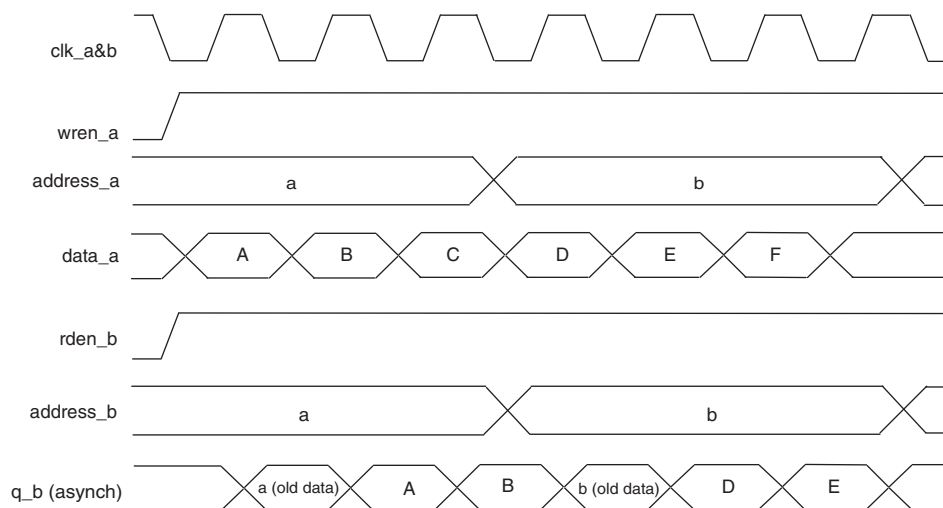

 For mixed-port read-during-write operation with dual clocks, the relationship between the clocks determines the output behavior of the memory. If you use the same clock for the two clocks, the output is the old data from the address location. However, if you use different clocks, the output is unknown during the mixed-port read-during-write operation. This unknown value may be the old or the new data at the address location, depending on whether the read happens before or after the write.

Conflict Resolution

When you are using M9K memory blocks in true dual-port mode, it is possible to attempt two write operations to the same memory location (address). Because there is no conflict resolution circuitry built into M9K memory blocks, this results in unknown data being written to that location. Therefore, you must implement conflict-resolution logic external to the M9K memory block.

Power-Up Conditions and Memory Initialization

The M9K memory block outputs of Cyclone III family devices power up to zero (cleared) regardless of whether the output registers are used or bypassed. All M9K memory blocks support initialization via a **.mif**. You can create **.mifs** in the Quartus II software and specify their use via the RAM MegaWizard Plug-In Manager when instantiating memory in your design. Even if memory is pre-initialized (for example, via **.mif**), it still powers up with its outputs cleared. Only the subsequent read after power up outputs the pre-initialized values.

 For more information on **.mifs**, refer to the *RAM Megafunction User Guide* and the *Quartus II Handbook*.

Power Management

The M9K memory block clock enables of Cyclone III family devices allow you to control clocking of each M9K memory block to reduce AC power consumption. Use the **rden** signal to ensure that read operations only occur when necessary. If your design does not require read-during-write, reduce power consumption by deasserting the **rden** signal during write operations, or any period when there are no memory operations. The Quartus II software automatically powers down any unused M9K memory blocks to save static power.

Chapter Revision History

Table 3-6 shows the revision history for this chapter.

Table 3-6. Chapter Revision History (Part 1 of 2)

Date and Document Version	Changes Made	Summary of Changes
June 2009 v2.0	<ul style="list-style-type: none"> ■ Updated chapter part number ■ Updated “Introduction” on page 3-1 ■ Updated “Overview” on page 3-1 ■ Updated Table 3-1 on page 3-2 ■ Updated “Control Signals” on page 3-3 ■ Updated “Memory Modes” on page 3-8 ■ Updated “Simple Dual-Port Mode” on page 3-10 ■ Updated “Read or Write Clock Mode” on page 3-16 	<ul style="list-style-type: none"> ■ Updated to include Cyclone III LS information
October 2008 v1.3	<ul style="list-style-type: none"> ■ Updated chapter to new template 	—
May 2008 v1.2	<ul style="list-style-type: none"> ■ Revised the maximum performance of the M9K blocks to 315 MHz in “Introduction” and “Overview” sections, and in Table 3-1 ■ Updated “Address Clock Enable Support” section 	—

Table 3-6. Chapter Revision History (Part 2 of 2)

Date and Document Version	Changes Made	Summary of Changes
July 2007 v1.1	■ Added chapter TOC and “Referenced Documents” section	—
March 2007 v1.0	■ Initial release	—



101 Innovation Drive
San Jose, CA 95134
www.altera.com
Technical Support
www.altera.com/support

Copyright © 2009 Altera Corporation. All rights reserved. Altera, The Programmable Solutions Company, the stylized Altera logo, specific device designations, and all other words and logos that are identified as trademarks and/or service marks are, unless noted otherwise, the trademarks and service marks of Altera Corporation in the U.S. and other countries. RSDS and PPDS are registered trademarks of National Semiconductor. All other product or service names are the property of their respective holders. Altera products are protected under numerous U.S. and foreign patents and pending applications, maskwork rights, and copyrights. Altera warrants performance of its semiconductor products to current specifications in accordance with Altera's standard warranty, but reserves the right to make changes to any products and services at any time without notice. Altera assumes no responsibility or liability arising out of the application or use of any information, product, or service described herein except as expressly agreed to in writing by Altera Corporation. Altera customers are advised to obtain the latest version of device specifications before relying on any published information and before placing orders for products or services.



I.S. EN ISO 9001