

This chapter describes the memory interface pin support and the external memory interface features of Cyclone® IV devices.

In addition to an abundant supply of on-chip memory, Cyclone IV devices can easily interface with a broad range of external memory devices, including DDR2 SDRAM, DDR SDRAM, and QDR II SRAM. External memory devices are an important system component of a wide range of image processing, storage, communications, and general embedded applications.

 Altera recommends that you construct all DDR2 or DDR SDRAM external memory interfaces using the Altera® ALTMEMPHY megafunction. You can implement the controller function using the Altera DDR2 or DDR SDRAM memory controllers, third-party controllers, or a custom controller for unique application needs. Cyclone IV devices support QDR II interfaces electrically, but Altera does not supply controller or physical layer (PHY) megafunctions for QDR II interfaces.

This chapter includes the following sections:

- “Cyclone IV Devices Memory Interfaces Pin Support” on page 7–2
- “Cyclone IV Devices Memory Interfaces Features” on page 7–12

 For more information about supported maximum clock rate, device and pin planning, IP implementation, and device termination, refer to the *External Memory Interface Handbook*.

Figure 7-1 shows the block diagram of a typical external memory interface data path in Cyclone IV devices.

Figure 7-1. Cyclone IV Devices External Memory Data Path (1)

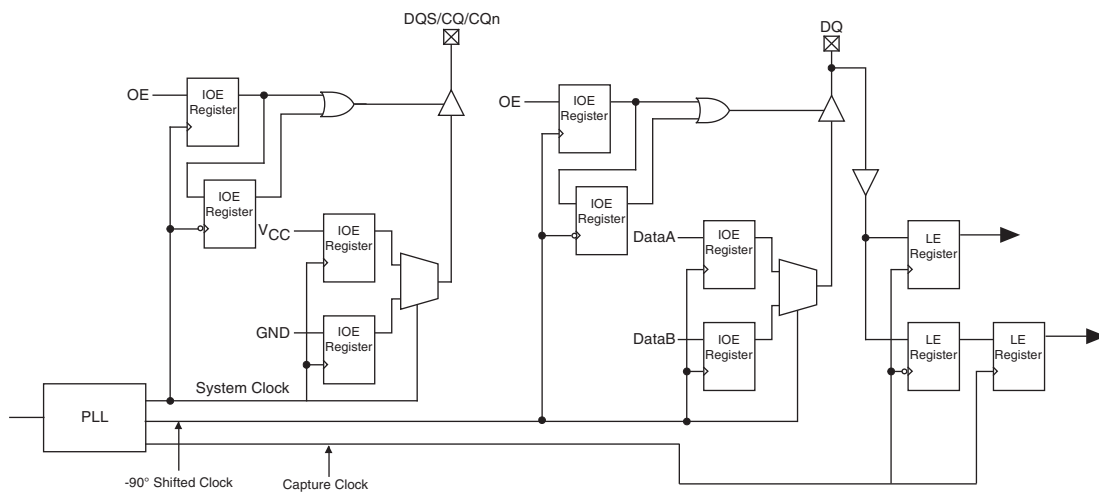

Note to Figure 7-1:

(1) All clocks shown here are global clocks.

For more information about implementing complete external memory interfaces, refer to the *External Memory Interface Handbook*.

Cyclone IV Devices Memory Interfaces Pin Support

Cyclone IV devices use data (DQ), data strobe (DQS), clock, command, and address pins to interface with external memory. Some memory interfaces use the data mask (DM) or byte write select (BWS#) pins to enable data masking. This section describes how Cyclone IV devices support all these different pins.

For more information about pin utilization, refer to *Volume 2: Device, Pin, and Board Layout Guidelines* of the *External Memory Interface Handbook*.

Data and Data Clock/Strobe Pins

Cyclone IV data pins for external memory interfaces are called D for write data, Q for read data, or DQ for shared read and write data pins. The read-data strobes or read clocks are called DQS pins. Cyclone IV devices support both bidirectional data strobes and unidirectional read clocks. Depending on the external memory standard, the DQ and DQS are bidirectional signals (in DDR2 and DDR SDRAM) or unidirectional signals (in QDR II SRAM). Connect the bidirectional DQ data signals to the same Cyclone IV devices DQ pins. For unidirectional D or Q signals, connect the read-data signals to a group of DQ pins and the write-data signals to a different group of DQ pins.

In QDR II SRAM, the Q read-data group must be placed at a different V_{REF} bank location from the D write-data group, command, or address pins.

In Cyclone IV devices, DQS is used only during write mode in DDR2 and DDR SDRAM interfaces. Cyclone IV devices ignore DQS as the read-data strobe because the PHY internally generates the read capture clock for read mode. However, you must connect the DQS pin to the DQS signal in DDR2 and DDR SDRAM interfaces, or to the CQ signal in QDR II SRAM interfaces.



Cyclone IV devices do not support differential strobe pins, which is an optional feature in the DDR2 SDRAM device.



When you use the Altera Memory Controller MegaCore[®] function, the PHY is instantiated for you. For more information about the memory interface data path, refer to the *External Memory Interface Handbook*.



ALTMEMPHY is a self-calibrating megafunction, enhanced to simplify the implementation of the read-data path in different memory interfaces. The auto-calibration feature of ALTMEMPHY provides ease-of-use by optimizing clock phases and frequencies across process, voltage, and temperature (PVT) variations. You can save on the global clock resources in Cyclone IV devices through the ALTMEMPHY megafunction because you are not required to route the DQS signals on the global clock buses (because DQS is ignored for read capture). Resynchronization issues do not arise because no transfer occurs from the memory domain clock (DQS) to the system domain for capturing data DQ.

All I/O banks in Cyclone IV devices can support DQ and DQS signals with DQ-bus modes of $\times 8$, $\times 9$, $\times 16$, $\times 18$, $\times 32$, and $\times 36$ except Cyclone IV GX devices that do not support left I/O bank interface. DDR2 and DDR SDRAM interfaces use $\times 8$ mode DQS group regardless of the interface width. For a wider interface, you can use multiple $\times 8$ DQ groups to achieve the desired width requirement.

In the $\times 9$, $\times 18$, and $\times 36$ modes, a pair of complementary DQS pins (CQ and CQ#) drives up to 9, 18, or 36 DQ pins, respectively, in the group, to support one, two, or four parity bits and the corresponding data bits. The $\times 9$, $\times 18$, and $\times 36$ modes support the QDR II memory interface. CQ# is the inverted read-clock signal that is connected to the complementary data strobe (DQS or CQ#) pin. You can use any unused DQ pins as regular user I/O pins if they are not used as memory interface signals.



For more information about unsupported DQS and DQ groups of the Cyclone IV transceivers that run at ≥ 2.97 Gbps data rate, refer to the *Cyclone IV Device Family Pin Connection Guidelines*.

Table 7-1 lists the number of DQS or DQ groups supported on each side of the Cyclone IV GX device.

Table 7-1. Cyclone IV GX Device DQS and DQ Bus Mode Support for Each Side of the Device ⁽¹⁾

Device	Package	Side	Number ×8 Groups	Number ×9 Groups	Number ×16 Groups	Number ×18 Groups	Number ×32 Groups	Number ×36 Groups
EP4CGX15	148-pin QFN	Right	1	0	0	0	—	—
		Top ⁽²⁾	1	0	0	0	—	—
		Bottom ⁽³⁾	1	0	0	0	—	—
	169-pin FBGA	Right	1	0	0	0	—	—
		Top ⁽²⁾	1	0	0	0	—	—
		Bottom ⁽³⁾	1	0	0	0	—	—
EP4CGX22 EP4CGX30	169-pin FBGA	Right	1	0	0	0	—	—
		Top ⁽²⁾	1	0	0	0	—	—
		Bottom ⁽³⁾	1	0	0	0	—	—
	324-pin FBGA	Right	2	2	1	1	—	—
		Top	2	2	1	1	—	—
		Bottom	2	2	1	1	—	—
	484-pin FBGA ⁽⁴⁾	Right	4	2	2	2	1	1
		Top	4	2	2	2	1	1
		Bottom	4	2	2	2	1	1
EP4CGX50 EP4CGX75	484-pin FBGA	Right	4	2	2	2	1	1
		Top	4	2	2	2	1	1
		Bottom	4	2	2	2	1	1
	672-pin FBGA	Right	4	2	2	2	1	1
		Top	4	2	2	2	1	1
		Bottom	4	2	2	2	1	1
EP4CGX110 EP4CGX150	484-pin FBGA	Right	4	2	2	2	1	1
		Top	4	2	2	2	1	1
		Bottom	4	2	2	2	1	1
	672-pin FBGA	Right	4	2	2	2	1	1
		Top	4	2	2	2	1	1
		Bottom	4	2	2	2	1	1
	896-pin FBGA	Right	6	2	2	2	1	1
		Top	6	2	3	3	1	1
		Bottom	6	2	3	3	1	1

Notes to Table 7-1:

- (1) The number of the DQS/DQ group is still preliminary.
- (2) Some of the DQ pins can be used as RUP and RDN pins. You cannot use these groups if you are using these pins as RUP and RDN pins for OCT calibration.
- (3) Some of the DQ pins can be used as RUP pins while the DM pins can be used as RDN pins. You cannot use these groups if you are using the RUP and RDN pins for OCT calibration.
- (4) Only available for EP4CGX30 device.

Table 7-2 lists the number of DQS or DQ groups supported on each side of the Cyclone IV E device.

Table 7-2. Cyclone IV E Device DQS and DQ Bus Mode Support for Each Side of the Device ⁽¹⁾ (Part 1 of 3)

Device	Package	Side	Number ×8 Groups	Number ×9 Groups	Number ×16 Groups	Number ×18 Groups	Number ×32 Groups	Number ×36 Groups
EP4CE6 EP4CE10	144-pin EQFP	Left	0	0	0	0	—	—
		Right	0	0	0	0	—	—
		Bottom ^{(2), (4)}	1	0	0	0	—	—
		Top ^{(2), (5)}	1	0	0	0	—	—
	256-pin UBGA	Left ⁽²⁾	1	1	0	0	—	—
		Right ⁽³⁾	1	1	0	0	—	—
		Bottom	2	2	1	1	—	—
		Top	2	2	1	1	—	—
	256-pin FBGA	Left ⁽²⁾	1	1	0	0	—	—
		Right ⁽³⁾	1	1	0	0	—	—
		Bottom	2	2	1	1	—	—
		Top	2	2	1	1	—	—
EP4CE15	144-pin EQFP	Left	0	0	0	0	—	—
		Right	0	0	0	0	—	—
		Bottom ^{(2), (4)}	1	0	0	0	—	—
		Top ^{(2), (5)}	1	0	0	0	—	—
	164-pin MBGA	Left	0	0	0	0	—	—
		Right	0	0	0	0	—	—
		Bottom ^{(2), (4)}	1	0	0	0	—	—
		Top ^{(2), (5)}	1	0	0	0	—	—
	256-pin UBGA	Left ⁽²⁾	1	1	0	0	—	—
		Right ⁽³⁾	1	1	0	0	—	—
		Bottom	2	2	1	1	—	—
		Top	2	2	1	1	—	—
	256-pin FBGA	Left ⁽²⁾	1	1	0	0	—	—
		Right ⁽³⁾	1	1	0	0	—	—
		Bottom	2	2	1	1	—	—
		Top	2	2	1	1	—	—
	484-pin FBGA	Left	4	4	2	2	1	1
		Right	4	4	2	2	1	1
		Bottom	4	4	2	2	1	1
		Top	4	4	2	2	1	1

Table 7–2. Cyclone IV E Device DQS and DQ Bus Mode Support for Each Side of the Device ⁽¹⁾ (Part 2 of 3)

Device	Package	Side	Number ×8 Groups	Number ×9 Groups	Number ×16 Groups	Number ×18 Groups	Number ×32 Groups	Number ×36 Groups
EP4CE22	144-pin EQFP	Left	0	0	0	0	—	—
		Right	0	0	0	0	—	—
		Bottom ^{(2), (4)}	1	0	0	0	—	—
		Top ^{(2), (5)}	1	0	0	0	—	—
	256-pin UBGA	Left ⁽²⁾	1	1	0	0	—	—
		Right ⁽³⁾	1	1	0	0	—	—
		Bottom	2	2	1	1	—	—
		Top	2	2	1	1	—	—
	256-pin FBGA	Left ⁽²⁾	1	1	0	0	—	—
		Right ⁽³⁾	1	1	0	0	—	—
		Bottom	2	2	1	1	—	—
		Top	2	2	1	1	—	—
EP4CE30 EP4CE115	484-pin FBGA	Left	4	4	2	2	1	1
		Right	4	4	2	2	1	1
		Bottom	4	4	2	2	1	1
		Top	4	4	2	2	1	1
	780-pin FBGA	Left	4	4	2	2	1	1
		Right	4	4	2	2	1	1
		Bottom	6	6	2	2	1	1
		Top	6	6	2	2	1	1

Table 7-2. Cyclone IV E Device DQS and DQ Bus Mode Support for Each Side of the Device ⁽¹⁾ (Part 3 of 3)

Device	Package	Side	Number ×8 Groups	Number ×9 Groups	Number ×16 Groups	Number ×18 Groups	Number ×32 Groups	Number ×36 Groups
EP4CE40 EP4CE55 EP4CE75	484-pin UBGA	Left	4	4	2	2	1	1
		Right	4	4	2	2	1	1
		Bottom	4	4	2	2	1	1
		Top	4	4	2	2	1	1
	484-pin FBGA	Left	4	4	2	2	1	1
		Right	4	4	2	2	1	1
		Bottom	4	4	2	2	1	1
		Top	4	4	2	2	1	1
	780-pin FBGA	Left	4	4	2	2	1	1
		Right	4	4	2	2	1	1
		Bottom	6	6	2	2	1	1
		Top	6	6	2	2	1	1

Notes to Table 7-2:

- (1) The number of the DQS/DQ group is still preliminary.
- (2) Some of the DQ pins can be used as RUP and RDN pins. You cannot use these groups if you are using these pins as RUP and RDN pins for OCT calibration.
- (3) Some of the DQ pins can be used as RUP pins while the DM pins can be used as RDN pins. You cannot use these groups if you are using the RUP and RDN pins for OCT calibration.
- (4) There is no DM pin support for these groups.
- (5) PLLCLKOUT3n and PLLCLKOUT3p pins are shared with the DQ or DM pins to gain ×8 DQ group. You cannot use these groups if you are using PLLCLKOUT3n and PLLCLKOUT3p.

 For more information about device package outline, refer to the [Device Packaging Specifications](#) webpage.

DQS pins are listed in the Cyclone IV pin tables as DQSXY, in which X indicates the DQS grouping number and Y indicates whether the group is located on the top (T), bottom (B), or right (R) side of the device. Similarly, the corresponding DQ pins are marked as DQXY, in which the X denotes the DQ grouping number and Y denotes whether the group is located on the top (T), bottom (B), or right (R) side of the device. For example, DQS2T indicates a DQS pin belonging to group 2, located on the top side of the device. Similarly, the DQ pins belonging to that group is shown as DQ2T.

 Each DQ group is associated with its corresponding DQS pins, as defined in the Cyclone IV pin tables. For example:

- For DDR2 or DDR SDRAM, ×8 DQ group DQ3B[7..0] pins are associated with the DQS3B pin (same 3B group index)
- For QDR II SRAM, ×9 Q read-data group DQ3T[8..0] pins are associated with DQS0T/CQ0T and DQS1T/CQ0T# pins (same 0T group index)

The Quartus® II software issues an error message if a DQ group is not placed properly with its associated DQS.

Figure 7-2 shows the location and numbering of the DQS, DQ, or CQ# pins in the Cyclone IV GX I/O banks.

Figure 7-2. DQS, CQ, or CQ# Pins in Cyclone IV GX I/O Banks (1)

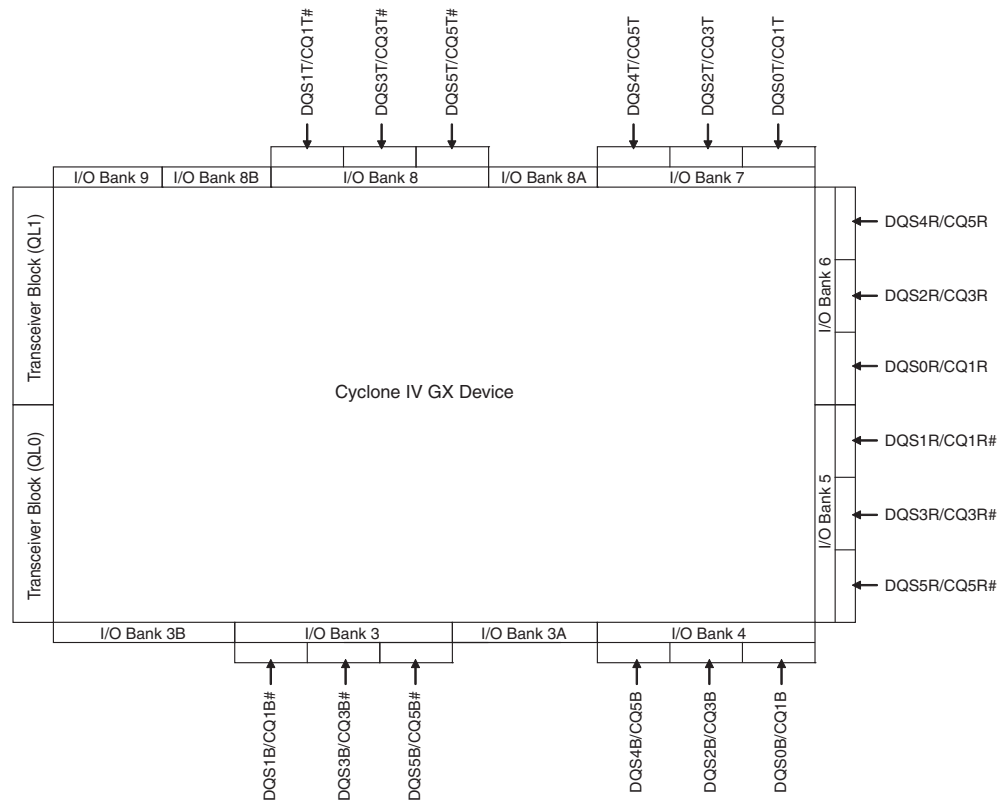

Note to Figure 7-2:

- (1) The DQS, CQ, or CQ# pin locations in this diagram apply to all packages in Cyclone IV GX devices except devices in 148-pin QFP, 169-pin FBGA, and 324-pin FBGA.

Figure 7-3 shows the location and numbering of the DQS, DQ, or CQ# pins in I/O banks of the Cyclone IV GX device in the 324-pin FBGA package only.

Figure 7-3. DQS, CQ, or CQ# Pins for Cyclone IV GX Devices in the 324-Pin FBGA Package

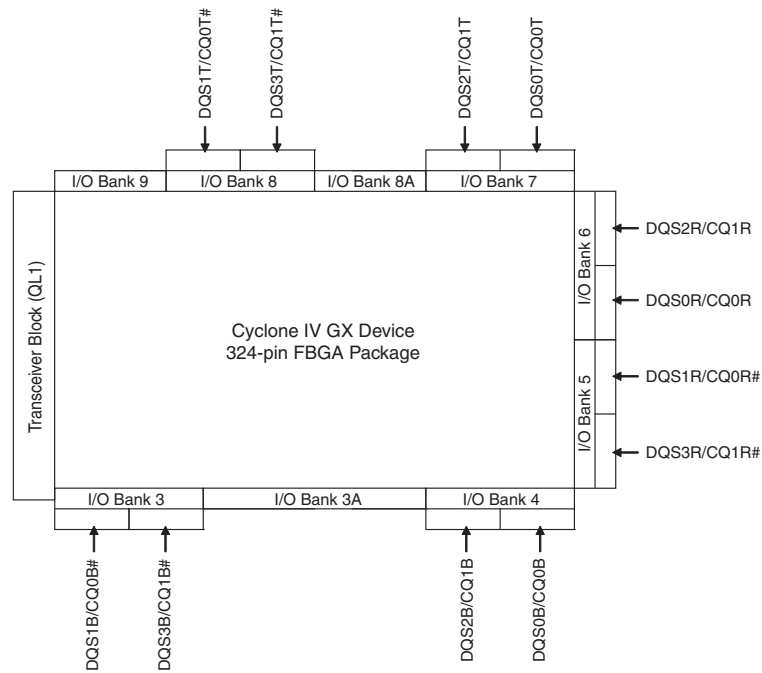

Figure 7-4 shows the location and numbering of the DQS, DQ, or CQ# pins in I/O banks of the Cyclone IV GX device in the 148-pin QFP and 169-pin FBGA packages.

Figure 7-4. DQS, CQ, or CQ# Pins for Cyclone IV GX Devices in the 148-Pin QFP and 169-Pin FBGA Packages

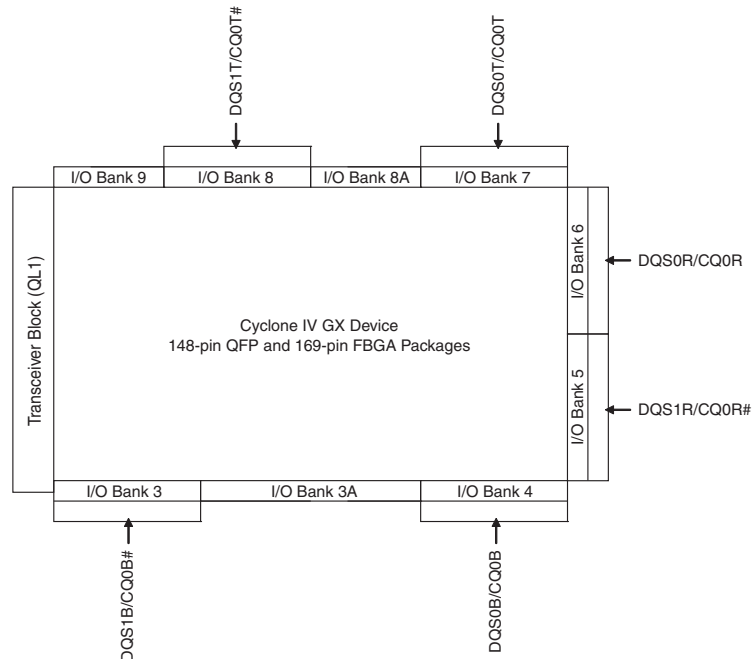
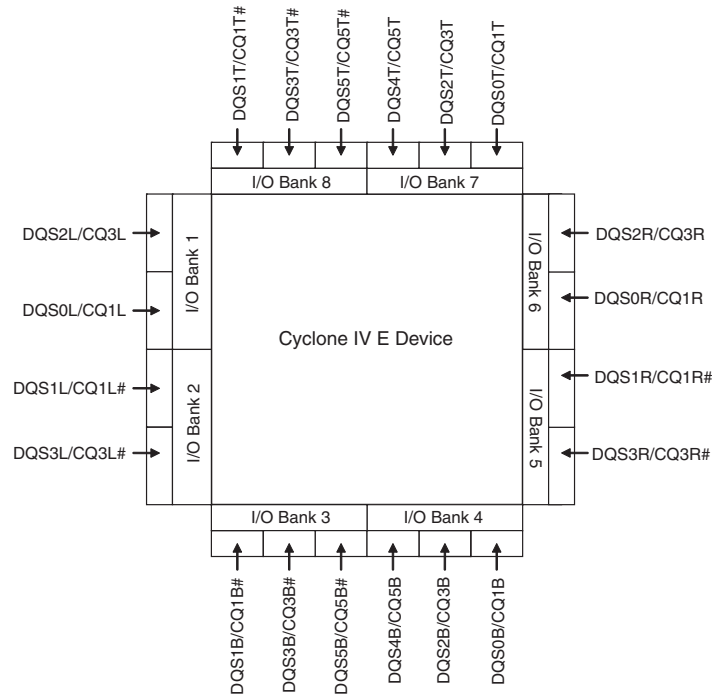

Figure 7-5 shows the location and numbering of the DQS, DQ, or CQ# pins in the Cyclone IV E device I/O banks.

Figure 7-5. DQS, CQ, or CQ# Pins in Cyclone IV E I/O Banks (1)



Note to Figure 7-5:

- (1) The DQS, CQ, or CQ# pin locations in this diagram apply to all packages in Cyclone IV E devices except devices in 144-pin EQFP.

Figure 7-6 shows the location and numbering of the DQS, DQ, or CQ# pins in I/O banks of the Cyclone IV E device in the 144-pin EQFP and 164-pin MBGA packages.

Figure 7-6. DQS, CQ, or CQ# Pins for Cyclone IV E Devices in the 144-Pin EQFP and 164-pin MBGA Packages

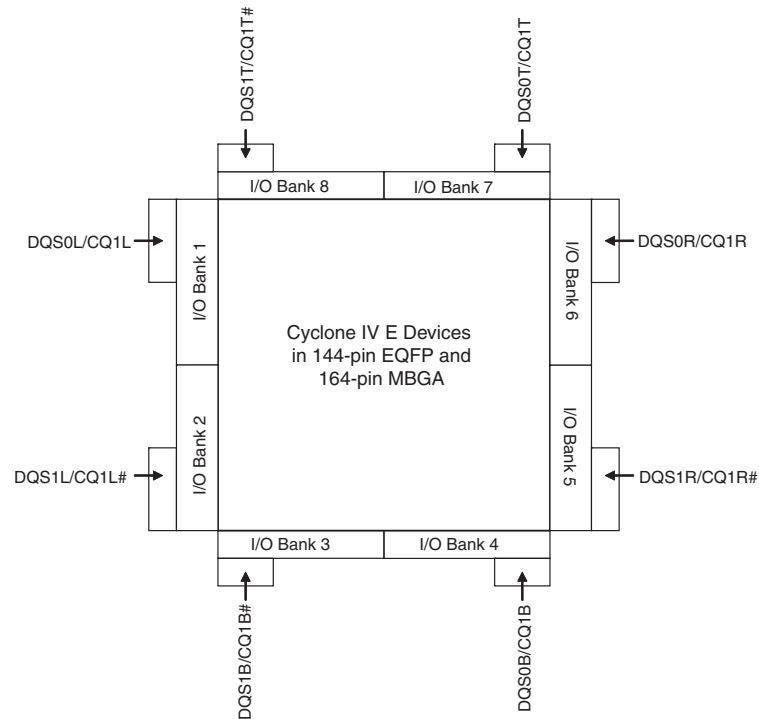

In Cyclone IV devices, the $\times 9$ mode uses the same DQ and DQS pins as the $\times 8$ mode, and one additional DQ pin that serves as a regular I/O pin in the $\times 8$ mode. The $\times 18$ mode uses the same DQ and DQS pins as $\times 16$ mode, with two additional DQ pins that serve as regular I/O pins in the $\times 16$ mode. Similarly, the $\times 36$ mode uses the same DQ and DQS pins as the $\times 32$ mode, with four additional DQ pins that serve as regular I/O pins in the $\times 32$ mode. When not used as DQ or DQS pins, the memory interface pins are available as regular I/O pins.

Optional Parity, DM, and Error Correction Coding Pins

Cyclone IV devices support parity in $\times 9$, $\times 18$, and $\times 36$ modes. One parity bit is available per eight bits of data pins. You can use any of the DQ pins for parity in Cyclone IV devices because the parity pins are treated and configured similarly to DQ pins.

DM pins are only required when writing to DDR2 and DDR SDRAM devices. QDR II SRAM devices use the BWS# signal to select the byte to be written into memory. A low signal on the DM or BWS# pin indicates the write is valid. Driving the DM or BWS# pin high causes the memory to mask the DQ signals. Each group of DQS and DQ signals has one DM pin. Similar to the DQ output signals, the DM signals are clocked by the -90° shifted clock.

In Cyclone IV devices, the DM pins are preassigned in the device pinouts. The Quartus II Fitter treats the DQ and DM pins in a DQS group equally for placement purposes. The preassigned DQ and DM pins are the preferred pins to use.

Some DDR2 SDRAM and DDR SDRAM devices support error correction coding (ECC), a method of detecting and automatically correcting errors in data transmission. In 72-bit DDR2 or DDR SDRAM, there are eight ECC pins and 64 data pins. Connect the DDR2 and DDR SDRAM ECC pins to a separate DQS or DQ group in Cyclone IV devices. The memory controller needs additional logic to encode and decode the ECC data.

Address and Control/Command Pins

The address signals and the control or command signals are typically sent at a single data rate. You can use any of the user I/O pins on all I/O banks of Cyclone IV devices to generate the address and control or command signals to the memory device.

 Cyclone IV devices do not support QDR II SRAM in the burst length of two.

Memory Clock Pins

In DDR2 and DDR SDRAM memory interfaces, the memory clock signals (CK and CK#) are used to capture the address signals and the control or command signals. Similarly, QDR II SRAM devices use the write clocks (K and K#) to capture the address and command signals. The CK/CK# and K/K# signals are generated to resemble the write-data strobe using the DDIO registers in Cyclone IV devices.

 CK/CK# pins must be placed on differential I/O pins (DIFFIO in Pin Planner) and in the same bank or on the same side as the data pins. You can use either side of the device for wraparound interfaces. As seen in the Pin Planner Pad View, CK0 cannot be located in the same row and column pad group as any of the interfacing DQ pins.

 For more information about memory clock pin placement, refer to *Volume 2: Device, Pin, and Board Layout Guidelines* of the *External Memory Interface Handbook*.

Cyclone IV Devices Memory Interfaces Features

This section discusses Cyclone IV memory interfaces, including DDR input registers, DDR output registers, OCT, and phase-lock loops (PLLs).

DDR Input Registers

The DDR input registers are implemented with three internal logic element (LE) registers for every DQ pin. These LE registers are located in the logic array block (LAB) adjacent to the DDR input pin.

Figure 7-7 illustrates Cyclone IV DDR input registers.

Figure 7-7. Cyclone IV DDR Input Registers

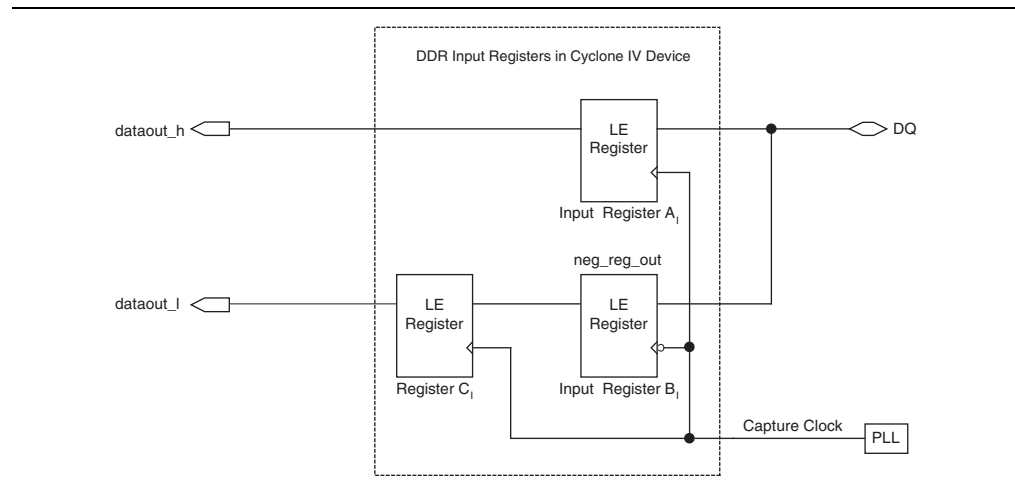

These DDR input registers are implemented in the core of devices. The DDR data is first fed to two registers, input register A₁ and input register B₁.

- Input register A₁ captures the DDR data present during the rising edge of the clock
- Input register B₁ captures the DDR data present during the falling edge of the clock
- Register C₁ aligns the data before it is synchronized with the system clock

The data from the DDR input register is fed to two registers, `sync_reg_h` and `sync_reg_l`, then the data is typically transferred to a FIFO block to synchronize the two data streams to the rising edge of the system clock. Because the read-capture clock is generated by the PLL, the read-data strobe signal (DQS or CQ) is not used during read operation in Cyclone IV devices; hence, postamble is not a concern in this case.

Figure 7-9 illustrates how the second output enable register extends the DQS high-impedance state by half a clock cycle during a write operation.

Figure 7-9. Extending the OE Disable by Half a Clock Cycle for a Write Transaction (1)

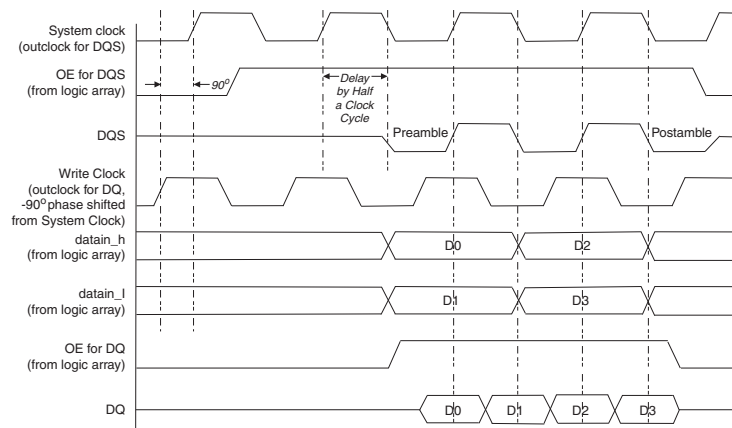

Note to Figure 7-9:

- (1) The waveform reflects the software simulation result. The OE signal is an active low on the device. However, the Quartus II software implements the signal as an active high and automatically adds an inverter before the A_{OE} register D input.

OCT with Calibration

Cyclone IV devices support calibrated on-chip series termination (R_S OCT) in both vertical and horizontal I/O banks. To use the calibrated OCT, you must use the RUP and RDN pins for each R_S OCT control block (one for each side). You can use each OCT calibration block to calibrate one type of termination with the same V_{CCIO} for that given side.

- For more information about the Cyclone IV devices OCT calibration block, refer to the *Cyclone IV Device I/O Features* chapter.

PLL

When interfacing with external memory, the PLL is used to generate the memory system clock, the write clock, the capture clock and the logic-core clock. The system clock generates the DQS write signals, commands, and addresses. The write-clock is shifted by -90° from the system clock and generates the DQ signals during writes. You can use the PLL reconfiguration feature to calibrate the read-capture phase shift to balance the setup and hold margins.

- The PLL is instantiated in the ALTMEMPHY megafunction. All outputs of the PLL are used when the ALTMEMPHY megafunction is instantiated to interface with external memories. PLL reconfiguration is used in the ALTMEMPHY megafunction to calibrate and track the read-capture phase to maintain the optimum margin.

- For more information about usage of PLL outputs by the ALTMEMPHY megafunction, refer to the *External Memory Interface Handbook*.

 For more information about Cyclone IV PLL, refer to the *Clock Networks and PLLs in Cyclone IV Devices* chapter.

Document Revision History

Table 7-3 lists the revision history for this chapter.

Table 7-3. Document Revision History

Date	Version	Changes
December 2010	2.2	<ul style="list-style-type: none"> ■ Updated for the Quartus II software version 10.1 release. ■ Added Cyclone IV E new device package information. ■ Updated Table 7-2. ■ Minor text edits.
November 2010	2.1	Updated “Data and Data Clock/Strobe Pins” section.
February 2010	2.0	<ul style="list-style-type: none"> ■ Added Cyclone IV E devices information for the Quartus II software version 9.1 SP1 release. ■ Updated Table 7-1. ■ Added Table 7-2. ■ Added Figure 7-5 and Figure 7-6.
November 2009	1.0	Initial release.