

Introduction

Back-end implementation of HardCopy® series devices meet design requirements through a timing closure process similar to the methodology used for today's standard cell ASICs.

The Quartus® II software provides a pre-layout estimation of your HardCopy design performance and then the Altera® HardCopy Design Center uses industry leading EDA software to complete the back-end layout and extract the final timing results prior to tape-out.



For more information on the HardCopy back-end design flow, refer to the *HardCopy Series Back-End Design Flow* chapter in the *HardCopy Series Device Handbook*.

This chapter describes how Altera ensures that HardCopy series devices meet their required timing performance.

Timing Analysis of HardCopy Prototype Device

You should perform timing analysis on the FPGA prototype implementation of the design before migrating to HardCopy. For HardCopy II designs, timing analysis should also be performed after successfully fitting the design in a HardCopy II device with Quartus II software. Timing analysis determines whether the design's performance meets the required timing goals.

The timing analysis must be done for both setup and hold time checks on all design paths, including internal paths and input and output paths. Measuring these parameters against performance goals ensures that the FPGA design functions as planned in the end-target system.



For more information on timing analysis of Altera devices, refer to the *Timing Analysis* section in volume 3 of the *Quartus II Handbook*.

After the FPGA design is stabilized, fully tested in-system and satisfies the HardCopy series design rules, the design can be migrated to a HardCopy series device. Altera performs rigorous timing analysis on the HardCopy series device during its implementation, ensuring that it meets the required timing goals. Because the critical timing paths of the HardCopy version of a design may be different from the corresponding paths in the FPGA version, meeting the required timing goals constrained in the Quartus II software is particularly important. Additional

performance gains are design dependent, and the percentage of performance improvement can be different for each clock domain of your design.

Timing differences between the FPGA design and the equivalent HardCopy series device can exist for several reasons. While maintaining the same set of features as the corresponding FPGA, HardCopy series devices have a highly optimized die size to make them as small as possible. Because of the customized interconnect structure that makes this optimization possible, the delay through each signal path is different from the original FPGA design.

Cell Structure

Meeting system timing goals in an ASIC design can be very challenging and can easily consume many months of engineering effort. The slower development process exists because, in today's silicon technology (0.18 μm , 0.13 μm , and 90 nm), the delay associated with interconnect dominates the delay associated with the transistors used to make the logic gates. Consequently, ASIC performance is sensitive to the physical placement and routing of the logic blocks that make up the design.

HardCopy II

HardCopy II devices use timing constraints to drive placement and routing of logic into the fabric of HCells. Each Stratix II Adaptive Look-up Table (ALUT) is implemented in HCell Macros in the HardCopy II device. HCell Macros are pre-defined and characterized libraries built out of HCells. The Quartus II software performs the placement and global routing of all HCell Macros and this information is forward-annotated to the HardCopy Design Center for final back-end implementation and timing closure.

HardCopy Stratix, HardCopy APEX

HardCopy Stratix® and HardCopy APEX™ are structurally identical to their respective FPGA counterparts. There is no re-synthesis or library re-mapping required. Since the interconnect lengths are much smaller in the HardCopy series device than they are in the FPGA, the place-and-route engine compiling the HardCopy series design has a considerably less difficult task than it does in an equivalent ASIC development. Coupled with detailed timing constraints, the place-and-route is timing driven.

Clock Tree Structure

The following section describes the clock tree structure for the HardCopy device family.

HardCopy II

HardCopy II devices offer a fine-grained architecture of HCells which are used to build HCell Macros for standard logic functions. The pre-built metal layers of HardCopy II devices contain the same global clock tree resources as those available in Stratix II devices, though they are smaller in HardCopy II devices because of the difference in die size. The top levels of the dedicated global clock networks in HardCopy II are pre-routed in the non-custom metal layers. The lowest level of clock tree buffering and routing is done using custom metal routing. Local buffering can be done using HCell Macros to fix any clock skew issues. HCell Macros are used to create registers, and local custom routing is needed to connect the clock networks to these HCell Macro registers. These tasks are performed as part of the HardCopy Design Center process.

HardCopy Stratix

HardCopy Stratix devices have the same global clock tree resources as Stratix FPGA devices. The construction of non-customizable layers of silicon minimizes global clock tree skew. HardCopy Stratix devices with clock trees using global clock resources have smaller clock insertion delay than Stratix FPGA devices because the HardCopy Stratix devices have a smaller die area. The use of clock tree synthesis to build small localized clock trees using the existing buffer resources in HardCopy Stratix devices automatically implements clock trees using fast regional clock resources in Stratix FPGA devices.

HardCopy APEX

The HardCopy APEX device architecture is based on the APEX 20KE and APEX 20KC devices. The same dedicated clock trees (CLK [3 . . 0]) that exist in APEX 20KE and APEX 20KC devices also exist in the corresponding HardCopy APEX device. These clock trees are carefully designed and optimized to minimize the clock skew over the entire device. The clock tree is balanced by maintaining the same loading at the end of each point of the clock tree, regardless of what resources (logic elements [LEs], embedded system blocks [ESBs], and input/output elements [IOEs]) are used in any design. The insertion delay of the HardCopy APEX dedicated clock trees is marginally faster than in the corresponding APEX 20KE or APEX 20KC FPGA device because of the smaller footprint of the HardCopy device silicon. This difference is less than 1 ns.

Because there is a large area overhead for the global signals that may not be used on every design, the FAST bidirectional pins (FAST [3..0]) do not have dedicated pre-built clock or buffer trees in HardCopy APEX devices. If any of the FAST signals are used as clocks, the place-and-route tool synthesizes a clock tree after the placement of the design has occurred. The skew and insertion delay of these synthesized clock trees is carefully controlled, ensuring that the timing requirements of the design are met. You can also use the FAST signals as high fan-out reset or enable signals. For these cases, skew is usually less important than insertion delay. To reiterate, a buffer tree is synthesized after the design placement.

The clock or buffer trees that are synthesized for the FAST pins are built out of special cells in the HardCopy APEX base design. These cells do not exist in the FPGA, and they are used in the HardCopy APEX design exclusively to meet timing and testing goals. They are not available to make any logical changes to the design as implemented in the FPGA. These resources are called the strip of auxiliary gates (SOAG). There is one strip per MegaLAB™ structure in HardCopy APEX devices. Each SOAG consists of a number of primitive cells, and there are approximately 10 SOAG primitive cells per logic array block (LAB). Several SOAG primitives can be combined to form more complex logic, but the majority of SOAG resources are used for buffer tree, clock tree, and delay cell generation.



For detailed information on the HardCopy APEX series device architecture, including SOAG resources, refer to the *HardCopy APEX Device Family Data Sheet* section in volume 1 of the *HardCopy Series Handbook*.

Importance of Timing Constraints

After capturing the information, Altera directly checks all timing of the HardCopy series device before tape-out occurs. It is important to constrain the FPGA and HardCopy devices for the exact timing requirements that need to be achieved. Timing violations seen in the Quartus II project or in the HardCopy Design Center migration process must be fixed or waived prior to the design being manufactured.

Correcting Timing Violations

After generating the customized metal interconnect for the HardCopy series device, Altera checks the design timing with a static timing analysis tool. The static timing analysis tool reports timing violations and then the HardCopy Design Center corrects the violations.

Hold-Time Violations

Because the interconnect in a HardCopy series device is customized for a particular application, it is possible that hold-time (tH) violations exist in the HardCopy series device after place-and-route occurs. A hold violation exists if the sum of the delay in the clock path between two registers plus the micro hold time of the destination register is greater than the delay of the data path from the source register to the destination register. The following equation describes this relationship.

$$tH \text{ slack} = \text{data delay} - \text{clock delay} - \mu tH$$

If a negative slack value exists, a hold-time violation exists. Any hold-time violation present in the HardCopy series design database after the interconnect data is generated is removed by inserting the appropriate delay in the data path. The inserted delay is large enough to guarantee no hold violation under fast, low-temperature, high-voltage conditions.

An Example HardCopy APEX Hold-Time Violation Fix

Table 4-1 shows an example report of a Synopsys PrimeTime static timing analysis of a HardCopy APEX design. The first report shows that the circuit has a hold-time violation and a negative slack value. The second result shows the timing report for the same path after fixing the hold violation. Part of the HardCopy implementation process is to generate the instance and cell names shown in these reports. The physical location of those elements in the device determines the generation of the names.

Table 4–1. HardCopy APEX Static Timing Analysis Before Hold-Time Violation Fix

Startpoint: GR23_GC0_L19_LE1/um6
(falling edge-triggered flip-flop clocked by CLK0')
Endpoint: GR23_GC0_L20_LE8/um6
(falling edge-triggered flip-flop clocked by CLK0')
Path Group: CLK0
Path Type: min

Point	Incr	Path	Reference Point (1)
clock CLK0' (fall edge)	0.00	0.00	
clock network delay (propagated)	2.15	2.15	(1)
GR23_GC0_L19_LE1/um6/clk (c1110)	0.00	2.15 f	(2)
GR23_GC0_L19_LE1/um6/regout (c1110)	0.36 *	2.52 r	(2)
GR23_GC0_L19_LE1/REGOUT (c1000_2d7a8)	0.00	2.52 r	(2)
GR23_GC0_L20_LE8/LUTD (c1000_56502)	0.00	2.52 r	(3)
GR23_GC0_L20_LE8/um1/datad (indsim)	0.01 *	2.52 r	(3)
GR23_GC0_L20_LE8/um1/ndsim (indsim)	0.01 *	2.53 f	(3)
GR23_GC0_L20_LE8/um5/ndsim (mxcascout)	0.00 *	2.53 f	(3)
GR23_GC0_L20_LE8/um5/cascout	0.06 *	2.59 f	(3)
GR23_GC0_L20_LE8/um6/dcout (c1110)	0.00 *	2.59 f	(3)
data arrival time		2.59	
clock CLK0' (fall edge)	0.00	0.00	
clock network delay (propagated)	2.17	2.17	(4)
clock uncertainty	0.25	2.42	(5)
GR23_GC0_L20_LE8/um6/clk (c1110)		2.42 f	(6)
library hold time	0.37 *	2.79	
data required time		2.79	
data arrival time		2.59	
data required time		-2.79	
slack (VIOLATED)		-0.20	

Note to Table 4–1:

- (1) This column does not exist in the actual report. It is included in this document to provide corresponding reference points to Figure 4–1.

Figure 4-1 shows the circuit described by the Table 4-1 static timing analysis report.

Figure 4-1. Circuit With a Hold-Time Violation

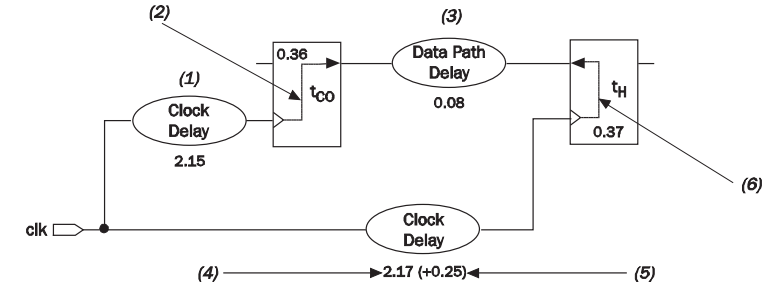

Placing the values from the static timing analysis report into the hold-time slack equation results in the following:

$$t_H \text{ slack} = \text{data delay} - \text{clock delay} - \mu t_H$$

$$t_H \text{ slack} = (2.15 + 0.36 + 0.08) - (2.17 + 0.25) - 0.37$$

$$t_H \text{ slack} = -0.20 \text{ ns}$$

This result shows that there is negative slack in this path, meaning that there is a hold-time violation of 0.20 ns.

After fixing the hold violation, the timing report for the same path is re-generated (Table 4-2). The netlist changes are in *bold italic* type.

Table 4–2. HardCopy APEX Static Timing Analysis After Hold-Time Violation Fix

Startpoint: GR23_GC0_L19_LE1/um6
(falling edge-triggered flip-flop clocked by CLK0')
Endpoint: GR23_GC0_L20_LE8/um6
(falling edge-triggered flip-flop clocked by CLK0')
Path Group: CLK0
Path Type: min
Static Timing Analysis After Hold-Time Violation Fix

Point	Incr	Path	Reference Point (1)
clock CLK0' (fall edge)	0.00	0.00	(1)
clock network delay (propagated)	2.15	2.15	(1)
GR23_GC0_L19_LE1/um6/clk (c1110)	0.00	2.15 f	(2)
GR23_GC0_L19_LE1/um6/regout (c1110)	0.36 *	2.52 r	(2)
GR23_GC0_L19_LE1/REGOUT (c1000_2d7a8)	0.00	2.52 r	(2)
thc_916/A (de105)	0.01 *	2.52 r	(3)
thc_916/Z (de105)	0.25 *	2.78 r	(3)
GR23_GC0_L20_LE8/LUTD (c1000_56502)	0.00	2.78 r	(3)
GR23_GC0_L20_LE8/um1/datad (indsim)	0.01 *	2.78 r	(3)
GR23_GC0_L20_LE8/um1/ndsim (indsim)	0.01 *	2.79 f	(3)
GR23_GC0_L20_LE8/um5/ndsim (mxscascout)	0.00 *	2.79 f	(3)
GR23_GC0_L20_LE8/um5/cascout (mxscascout)	0.06 *	2.85 f	(3)
GR23_GC0_L20_LE8/um6/dcout (c1110)	0.00 *	2.85 f	(3)
data arrival time		2.85	
clock CLK0' (fall edge)	0.00	0.00	
clock network delay (propagated)	2.17	2.17	(4)
clock uncertainty	0.25	2.42	(5)
GR23_GC0_L20_LE8/um6/clk (c1110)		2.42 f	(6)
library hold time	0.37 *	2.79	
data required time		2.79	
data arrival time		2.85	
data required time		-2.79	
slack (MET)		0.06	

Note to Table 4–2:

- (1) This column does not exist in the actual report. It is included in this document to provide corresponding reference points to [Figure 4–2](#).

Figure 4–2 shows the circuit described by the Table 4–2 static timing analysis report.

Figure 4–2. Circuit Including a Fixed Hold-Time Violation

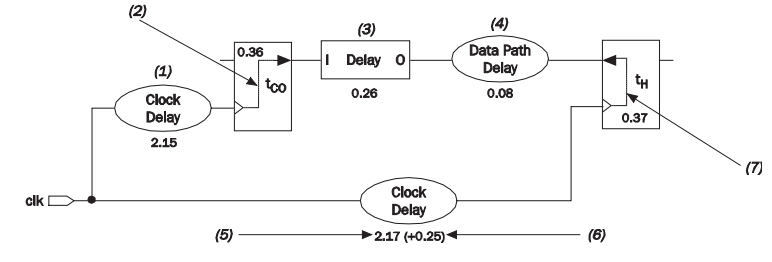

Placing the values from the static timing analysis report into the hold-time slack equation, results in the following.

$$t_H \text{ slack} = \text{data delay} - \text{clock delay} - \mu t_H$$

$$t_H \text{ slack} = (2.15 + 0.36 + 0.26 + 0.08) - (2.17 + 0.25) - 0.37$$

$$t_H \text{ slack} = + 0.06 \text{ ns}$$

In this timing report, the slack of this path is reported as 0.06 ns. Therefore, this path does not have a hold-time violation. This path was fixed by the insertion of a delay cell (de105) into the data path, which starts at the REGOUT pin of cell GR23_GC0_L19_LE1 and finishes at the LUTD input of cell GR23_GC0_L20_LE8. The instance name of the delay cell in this case is thc_916.



This timing report specifies a clock uncertainty of 0.25 ns, and adds extra margin during the hold-time calculation, making the design more robust. This feature is a part of the static timing analysis tool, not of the HardCopy series design.

The SOAG resources that exist in the HardCopy APEX base design create the delay cell. The HardCopy Stratix base design contains auxiliary buffer cells of varying drive strength used to fix setup and hold time violations.

Setup-Time Violations

A setup violation exists if the sum of the delay in the data path between two registers plus the micro setup time (t_{SU}) of the destination register is greater than the sum of the clock period and the clock delay at the destination register. The following equation describes this relationship:

$$t_{SU} \text{ slack} = \text{clock period} + \text{clock delay} - (\text{data delay} + \mu t_{SU})$$

If there is a negative slack value, a setup-time violation exists. Several potential mechanisms can cause a setup-time violation. The first is when the synthesis tool is unable to meet the required timing goals. However, a HardCopy series design does not rely on any re-synthesis to a new cell library; synthesis results are generated as part of the original FPGA design, meaning that the HardCopy implementation of a design uses exactly the same structural netlist as its FPGA counterpart. For example, if you used a particular synthesis option to ensure that a particular path only contain a certain number of logic levels, the HardCopy series design contains exactly the same number of logic levels for that path. Consequently, if the FPGA was free of setup-time violations, no setup-time violations will occur in the HardCopy series device due to the netlist structure.

The second mechanism that can cause setup-time violations is differing placement of the resources in the netlist for the HardCopy series device compared to the original FPGA. This scenario is extremely unlikely as the place-and-route tool used during the HardCopy implementation performs timing-driven placement. In extreme cases, some manual placement modifications are necessary. The placement is performed at the LAB and ESB level, meaning that the placement of logic cells inside each LAB is fixed, and is identical to the placement of the FPGA. IOEs have fixed placement to maintain the pin and package compatibility of the original FPGA.

The third, and most likely, mechanism for setup-time violations occurring in the HardCopy series device is a signal with a high fan-out. In the FPGA, high fan-out signals are buffered by large drivers that are integral parts of the programmable interconnect structure. Consequently, a signal that was fast in the FPGA can be initially slower in the HardCopy version. The place-and-route tool detects these signals and automatically creates buffer trees using SOAG resources, ensuring that the heavily loaded, high fan-out signal is fast enough to meet performance requirements.

An Example HardCopy APEX Setup-Time Violation Fix

Table 4-3 shows the timing report for a path in a HardCopy APEX design that contains a high fan-out signal before the place-and-route process.

Table 4-4 shows the timing report for a path that contains a high fan-out signal after the place-and-route process. Before the place-and-route process, there is a large delay on the high fan-out net driven by the pin GR12_GC0_L2_LE4/REGOUT. This delay is due to the large capacitive load that the pin has to drive. Figure 4-3 shows the timing report information.

Table 4-3. HardCopy APEX Timing Report Before Place-and-Route Process

Startpoint: GR12_GC0_L2_LE4/um6 (falling edge-triggered flip-flop clocked by clkx')			
Endpoint: GR4_GC0_L5_LE2/um6 (falling edge-triggered flip-flop clocked by clkx')			
Path Group: clkx			
Path Type: max			
Point	Incr	Path	Reference Point (1)
clock clkx' (fall edge)	0.00	0.00	(1)
clock network delay (propagated)	2.18	2.18	(1)
GR12_GC0_L2_LE4/um6/clk (c1110)	0.00	2.18 f	(2)
GR12_GC0_L2_LE4/um6/regout (c1110)			(2)
GR12_GC0_L2_LE4/REGOUT (c1000_7f802) <-			(2)
GR4_GC0_L5_LE0/LUTC (c1000_0029a)			(3)
GR4_GC0_L5_LE0/um4/ltb (lt53b)	2.36	9.18 f	(3)
GR4_GC0_L5_LE0/um5/cascout (mxscascout)	0.07	9.24 f	(3)
GR4_GC0_L5_LE0/um2/COMBOUT (icombout)	0.09	9.34 r	(3)
GR4_GC0_L5_LE0/COMBOUT (c1000_0029a)	0.00	9.34 r	(3)
GR4_GC0_L5_LE2/LUTC (c1000_0381a)	0.00	9.34 r	(3)
GR4_GC0_L5_LE2/um4/ltb (lt03b)	0.40	9.73 r	(3)
GR4_GC0_L5_LE2/um5/cascout (mxscascout)	0.05	9.78 r	(3)
GR4_GC0_L5_LE2/um6/dcout (c1110)	0.00	9.78 r	(3)
data arrival time		9.79	(3)
clock clkx' (fall edge)	7.41	7.41	
clock network delay (propagated)	2.18	9.59	(4)
clock uncertainty	-0.25	9.34	(5)
GR4_GC0_L5_LE2/um6/clk (c1110)		9.34 f	
Point	Incr	Path	Reference Point (1)
library setup time	-0.18	9.16	(6)
data required time		9.16	
data required time		9.16	
data arrival time		-9.79	
slack (VIOLATED)		-0.63	

Note to Table 4-3:

- (1) This column does not exist in the actual report. It is included in this document to provide corresponding reference points to Figure 4-3.

Figure 4-3 shows the circuit that Table 4-3 static timing analysis report describes.

Figure 4-3. Circuit That Has a Setup-Time Violation

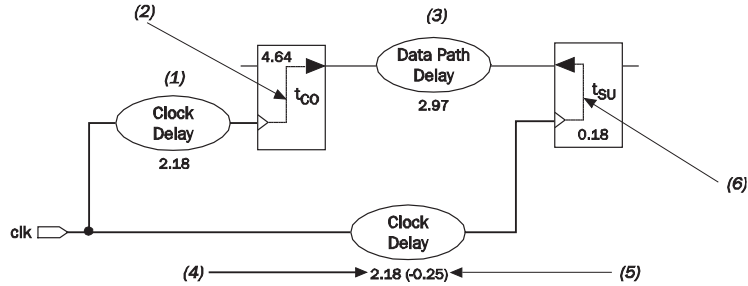

 The timing numbers in this report are based on pre-layout estimated delays.

Placing the values from the static timing analysis report into the set-up time slack equation, results in the following.

$$t_{SU} \text{ slack} = \text{clock period} + \text{clock delay} - (\text{data delay} + \mu t_{SU})$$

$$t_{SU} \text{ slack} = 7.41 + (2.18 - 0.25) - (2.18 + 4.64 + 2.97 + 0.18)$$

$$t_{SU} \text{ slack} = -0.63 \text{ ns}$$

This result shows that there is negative slack for this path, meaning that there is a setup-time violation of 0.63 ns.

After place-and-route, a buffer tree is constructed on the high fan-out net and the setup-time violation is fixed. Table 4-4 shows the timing report for the same path. The changes to the netlist are in **bold italic** type. Figure 4-4 shows more information on this timing report.

Table 4-4. HardCopy APEX Timing Report After the Place-and-Route Process

Startpoint: GR12_GC0_L2_LE4/um6 (falling edge-triggered flip-flop clocked by clk')			
Endpoint: GR4_GC0_L5_LE2/um6 (falling edge-triggered flip-flop clocked by clk')			
Path Group: clkx			
Path Type: max			
Point	Incr	Path	Reference Point (1)
clock clkx' (fall edge)	0.00	0.00	
clock network delay (propagated)	2.73	2.73	(1)
GR12_GC0_L2_LE4/um6/clk (c1110)	0.00	2.73 f	(2)
GR12_GC0_L2_LE4/um6/regout (c1110)	0.69 *	3.42 r	(2)
GR12_GC0_L2_LE4/REGOUT (c1000_7f802) <-	0.00	3.42 r	(2)
N1188_iv06_1_0/Z (iv06)	0.06 *	3.49 f	(3)
N1188_iv06_2_0/Z (iv06)	0.19 *	3.68 r	(3)
N1188_iv06_3_0/Z (iv06)	0.12 *	3.80 f	(3)
N1188_iv06_4_0/Z (iv06)	0.10 *	3.90 r	(3)
N1188_iv06_5_0/Z (iv06)	0.08 *	3.97 f	(3)
N1188_iv06_6_2/Z (iv06)	1.16 *	5.13 r	(3)
GR4_GC0_L5_LE0/LUTC (c1000_0029a)	0.00	5.13 r	(4)
GR4_GC0_L5_LE0/um4/ltb (lt53b)	1.55 *	6.68 f	(4)
GR4_GC0_L5_LE0/um5/cascout (mxscascout)	0.06 *	6.74 f	(4)
GR4_GC0_L5_LE0/um2/COMBOUT (icombout)	0.09 *	6.84 r	(4)
GR4_GC0_L5_LE0/COMBOUT (c1000_0029a)	0.00	6.84 r	(4)
GR4_GC0_L5_LE2/LUTC (c1000_0381a)	0.00	6.84 r	(4)
GR4_GC0_L5_LE2/um4/ltb (lt03b)	0.40 *	7.24 r	(4)
GR4_GC0_L5_LE2/um5/cascout (mxscascout)	0.05 *	7.28 r	(4)
GR4_GC0_L5_LE2/um6/dcout (c1110)	0.00 *	7.28 r	(4)
data arrival time		7.28	(4)
Point	Incr	Path	Reference Point (1)
clock clkx' (fall edge)	7.41	7.41	
clock network delay (propagated)	2.74	10.15	(5)
clock uncertainty	-0.25	9.90	(6)
GR4_GC0_L5_LE2/um6/clk (c1110)		9.90 f	
library setup time	-0.20 *	9.70	(7)
data required time		9.70	
data required time		9.70	
data arrival time		-7.28	
slack (MET)		2.42	

Note to Table 4-4:

(1) This column does not exist in the actual report. It is included in this document to provide corresponding reference points to Figure 4-4.

The GR12_GC0_L2_LE4/REGOUT pin now has the loading on it reduced by the introduction of several levels of buffering (in this case, six levels of inverters). The inverters have instance names similar to N1188_iv06_1_0, and are of type iv06, as shown in the static timing analysis report. As a result, the original setup-time violation of -0.63 ns turned into a slack of $+2.42$ ns, meaning the setup-time violation is fixed. Figure 4-4 illustrates the circuit that the static timing analysis report shows. The buffer tree (buffer) is shown as a single cell.

Figure 4-4. Circuit Post Place-and-Route

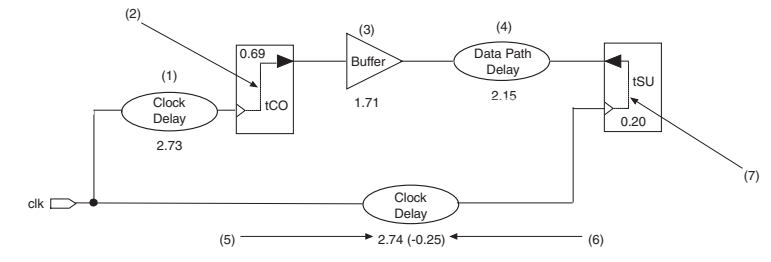

Placing the values from the static timing analysis report into the setup-time slack equation, results in the following:

$$t_{\text{SU}} \text{ slack} = \text{clock period} + \text{clock delay} - (\text{data delay} + \mu t_{\text{SU}})$$

$$t_{\text{SU}} \text{ slack} = 7.41 + (2.74 - 0.25) - (2.73 + 0.69 + 1.71 + 2.15 + 0.20)$$

$$t_{\text{SU}} \text{ Slack} = +2.42 \text{ ns}$$

This result shows that there is positive slack for this path, meaning that there is now no setup-time violation.

Timing ECOs

In an ASIC, small incremental changes to a design database are termed engineering change orders (ECOs). In the HardCopy series design flow, ECOs are performed after the initial post-layout timing data is available.

You run static timing analysis on the design, which generates a list of paths with timing violations. An automatically updated netlist reflects changes that correct these timing violations (for example, the addition of delay cells to fix hold-time violations). After the netlist update, the updated place-and-route database reflects the netlist changes. The impact to this database is made minimal by maintaining all of the pre-existing placement and routing, and only changing the routing of newly inserted cells.

The parasitic (undesirable, but unavoidable) resistances and capacitances of the customized interconnect are extracted, and are used in conjunction with the static timing analysis tool to re-check the timing of the design. Detected crosstalk violations on signals are fixed by adding additional buffering to increase the setup or hold margin on victim signals. In-line buffering and small buffer tree insertion is done for signals with high fan-out, high transition times, or high capacitive loading. Figure 4-5 shows this flow in more detail.

Figure 4-5. ECO Flow Diagram

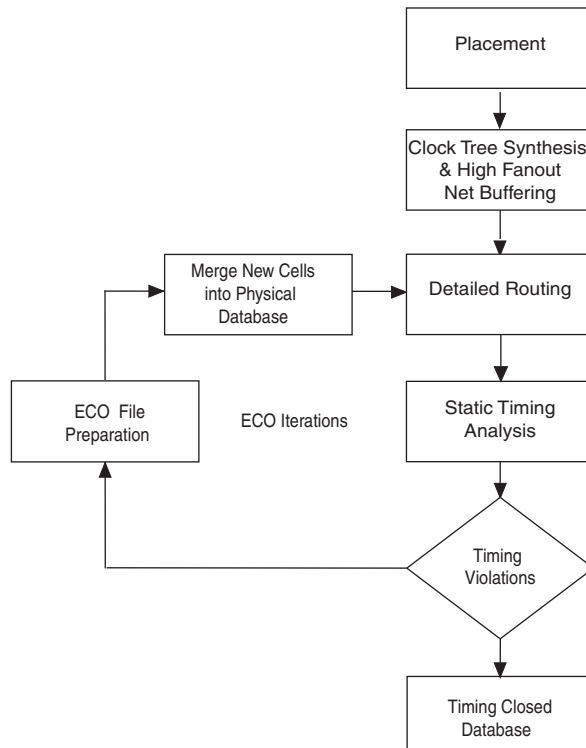

The back-end flow in HardCopy produces the final sign-off timing for your HardCopy device. The Quartus II software produces the timing report for HardCopy based on a global route and does not factor in exact physical parasitics of the routed nets, nor does it factor in the crosstalk effect that neighboring nets can have on interconnect capacitance.

Conclusion

It is critical that you fully constrain your HardCopy series design for timing. Although HardCopy series devices are functionally equivalent to their FPGA prototype companion, they have inevitable timing differences. Fully constrained timing paths are a cornerstone of designing for HardCopy series devices.

Consult with Altera if you have questions on what areas to concentrate your efforts in to achieve timing closure within the Quartus fitter for HardCopy design submission.

Document Revision History

Table 4-5 shows the revision history for this chapter.

Date and Document Version	Changes Made	Summary of Changes
September 2008, v2.4	Updated chapter number and metadata.	—
June 2007, v2.3	Minor text edits.	—
December 2006 v2.2	<ul style="list-style-type: none"> • Minor updates for the Quartus II software version 6.1.0 • Moved <i>Checking the HardCopy Series Device Timing</i> section to Chapter 7 	A minor update to the chapter, due to changes in the Quartus II software version 6.1 release; also, <i>Checking the HardCopy Series Device Timing</i> section moved to Chapter 7.
March 2006	Formerly chapter 17; no content change.	—
October 2005 v2.1	<ul style="list-style-type: none"> • Moved <i>Chapter 16 Back-End Timing Closure for Hardcopy Series Devices</i> to Chapter 17 in <i>HardCopy Series Device Handbook</i> release 3.2 • Updated graphics • Minor edits 	—

Table 4–5. Document Revision History (Part 2 of 2)

Date and Document Version	Changes Made	Summary of Changes
January 2005 v2.0	<ul style="list-style-type: none"> ● Chapter title changed to <i>Back-End Timing Closure for HardCopy Series Devices</i>. ● Sizes of silicon technology updated in “Timing Closure” on page 17–2. ● HardCopy® Stratix® and HardCopy APEX™ equivalence to their respective FPGA is updated on page 17–2. ● Stratix II migration added. ● Updated Table 17–2 on page 17–12. ● Updated last paragraph in “Timing ECOs” on page 17–18. 	—
June 2003 v1.0	Initial release of Chapter 17, Back-End Timing Closure for HardCopy Series Devices.	—