



3. Transitioning APEX Designs to Stratix & Stratix GX Devices

S52012-3.0

Introduction

Stratix® and Stratix GX devices are Altera's next-generation, system-on-a-programmable-chip (SOC) solution. Stratix and Stratix GX devices simplify the block-based design methodology and bridge the gap between system bandwidth requirements and programmable logic performance.

This chapter highlights the new features in the Stratix and Stratix GX devices and provides assistance when transitioning designs from APEX™ II or APEX 20K devices to the Stratix or Stratix GX architecture. Designers using this chapter should be familiar with the APEX II or APEX 20K architecture and available device features. Use this chapter in conjunction with the *Stratix Device Family Data Sheet* section of the *Stratix Device Handbook, Volume 1* or the *Stratix GX Device Family Data Sheet* section of the *Stratix GX Device Handbook, Volume 1*.

General Architecture

Stratix and Stratix GX devices offer many new features and architectural enhancements. Enhanced logic elements (LEs) and the MultiTrack™ interconnect structure offer reduced resource utilization and considerable design performance improvement. The MultiTrack interconnect uses DirectDrive™ technology to ensure the availability of deterministic routing resources for any design block, regardless of its placement within the device.

All architectural changes between Stratix and Stratix GX and APEX II or APEX 20K devices described in this section do not require any design changes. However, you must resynthesize your design and recompile in the Quartus® II software to target Stratix and Stratix GX devices.

Logic Elements

Stratix and Stratix GX device LEs include several new, advanced features that improve design performance and reduce logic resource consumption (see [Table 3–1](#)). The Quartus II software automatically uses these new LE features to improve device utilization.

Feature	Function	Benefit
Register chain interconnects	Direct path between the register output of an LE and the register input of an adjacent LE within the same logic array block (LAB)	<ul style="list-style-type: none"> ■ Conserves LE resources ■ Provides fast shift register implementation ■ Saves local interconnect routing resources within an LAB
Look-up table (LUT) chain interconnects	Direct path between the combinatorial output of an LE and the fast LUT input of an adjacent LE within the same LAB	<ul style="list-style-type: none"> ■ Allows LUTs within the same LAB to cascade together for high-speed wide fan-in functions, such as wide XOR operations ■ Bypasses local interconnect for faster performance
Register-to-LUT feedback path	Allows the register output to feed back into the LUT of the same LE, such that the register is packed with its own fan-out LUT	<ul style="list-style-type: none"> ■ Enhanced register packing mode ■ Uses resources more efficiently
Dynamic arithmetic mode	Uses one set of LEs for implementing both an adder and subtractor	<ul style="list-style-type: none"> ■ Improves performance for functions that switch between addition and subtraction frequently, such as correlators
Carry-select chain	Calculates outputs for a possible carry-in of 1 or 0 in parallel	<ul style="list-style-type: none"> ■ Gives immediate access to result for both a carry-in of 1 or 0 ■ Increases speed of carry functions for high-speed operations, such as counters, adders, and comparators
Asynchronous clear and asynchronous preset function	Supports direct asynchronous clear and preset functions	<ul style="list-style-type: none"> ■ Conserves LE resources ■ Does not require additional logic resources to implement NOT-gate push-back

In addition to the new LE features described in [Table 3–1](#), there are enhancements to the chains that connect LEs together. Carry chains are implemented vertically in Stratix and Stratix GX devices, instead of horizontally as in APEX II and APEX 20K devices, and continue across rows, instead of across columns, as shown in [Figure 3–1](#). Also note that the Stratix and Stratix GX architectures do not support the cascade primitive. Therefore, the Quartus II Compiler automatically converts

cascade primitives in APEX II and APEX 20K designs to a wire primitive when compiled for Stratix and Stratix GX devices. These architectural changes are transparent to the user and do not require design changes.

Figure 3–1. Carry Chain Implementation in APEX II & APEX 20K Devices vs. Stratix & Stratix GX Devices

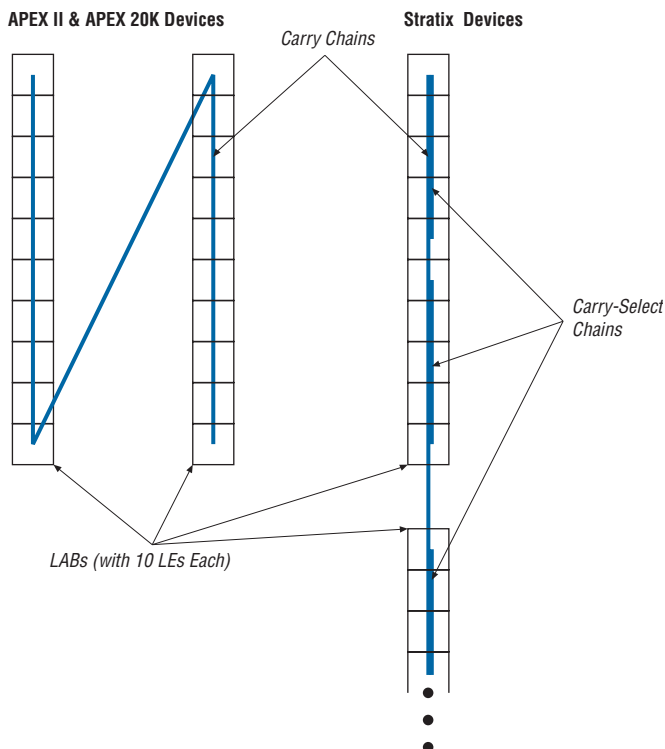

MultiTrack Interconnect

Stratix and Stratix GX devices use the MultiTrack interconnect structure to provide a high-speed connection between logic resources using performance-optimized routing channels of different lengths. This feature maximizes overall design performance by placing critical paths on routing lines with greater speed, resulting in minimal propagation delay.

Stratix and Stratix GX device MultiTrack interconnect resources are described in [Table 3–2](#).

Routing Type	Interconnect	Span
Row	Direct link	Adjacent LABs and/or blocks
Row	R4	Four LAB units horizontally
Row	R8	Eight LAB units horizontally
Row	R24	Horizontal routing across the width of the device
Column	C4	Four LAB units vertically
Column	C8	Eight LAB units vertically
Column	C16	Vertical routing across the length of the device

Direct link routing saves row routing resources while providing fast communication paths between resource blocks. Direct link interconnects allow an LAB, digital signal processing (DSP) block, or TriMatrix™ memory block to drive data into the local interconnect of its left and right neighbors. LABs, DSP blocks, and TriMatrix memory blocks can also use direct link interconnects to drive data back into themselves for feedback.

The Quartus II software automatically uses these routing resources to enhance design performance.



For more information about LE architecture and the MultiTrack interconnect structure in Stratix and Stratix GX devices, see the *Stratix Device Family Data Sheet* section of the *Stratix Device Handbook, Volume 1* or the *Stratix GX Device Family Data Sheet* section of the *Stratix GX Device Handbook, Volume 1*.

DirectDrive Technology

When using APEX II or APE 20K devices, you must place critical paths in the same MegaLAB™ column to improve performance. Additionally, you should place critical paths in the same MegaLAB structure for optimal performance. However, this restriction does not exist in Stratix and Stratix GX devices because they do not contain MegaLAB structures. With the new DirectDrive™ technology in Stratix and Stratix GX devices, the actual distance between the source and destination of a path is the most important criteria for meeting timing performance. DirectDrive technology ensures that the same routing resources are available to each design block, regardless of its location in the device.

Architectural Element Names

The architectural element naming system within Stratix and Stratix GX devices differs from the row-column coordinate system (for example, LC1_A2, LAB_B1) used in previous Altera device families. Stratix and Stratix GX devices use a new naming system based on the X-Y coordinate system, (X, Y). A number (N) designates the location within the block where the logic resides, such as LEs within an LAB. Because the Stratix and Stratix GX architectures are column-based, this naming simplifies location assignments. Stratix and Stratix GX architectural blocks include:

- LAB: logic array block
- DSP: digital signal processing block
- DSPOUT: adder/subtractor/accumulator or summation block of the DSP block
- M512: 512-bit memory block
- M4K: 4-Kbit memory block
- M-RAM: 512-Kbit memory block

Elements within architectural blocks include:

- LE: logic element
- IOC: I/O element
- PLL: phase-locked loop
- DSPMULT: DSP block multiplier
- SERDESTX: transmitter serializer/deserializer
- SERDESRX: receiver serializer/deserializer

Table 3–3 highlights the new location syntax used for Stratix and Stratix GX devices.

Architectural Elements	Element Name	Location Syntax	Example of Location Syntax	
			Location	Description
Blocks	LAB, DSP, DSPOUT, M512, M4K, M-RAM	<element_name>_X<number>_Y<number>	LAB_X1_Y1	Designates the LAB in row 1, column 1
Logic	LE, IOC, PLL, DSPMULT, SERDESTX, SERDESX	<element_name>_X<number>_Y<number>_N<number>	LC_X1_Y1_N0	Designates the first LE, N0, in the LAB located in row 1, column 1
Pins (1)	I/O pins	pin_<pin_label>	pin_5	Pin 5

Note to Table 3–3:

(1) You can make assignments to I/O pads using IOC_X<number>_Y<number>_N<number>.

Use the following guidelines with the new naming system:

- The anchor point, or origin, in Stratix and Stratix GX devices is in the bottom-left corner, instead of the top-left corner as in APEX II and APEX 20K devices.
- The anchor point, or origin, of a large block element (e.g., a M-RAM or DSP block) is also the bottom-left corner.
- All numbers are zero-based, meaning the origin at the bottom-left of the device is X0, Y0.
- The I/O pins constitute the first and last rows and columns in the X-Y coordinates. Therefore, the bottom row of pins resides in X<number>, Y0, and the first left column of pins resides in X0, Y<number>.
- The sub-location of elements, N, numbering begins at the top. Therefore, the LEs in an LAB are still numbered from top to bottom, but start at zero.

Figure 3–2 show the Stratix and Stratix GX architectural element numbering convention. Figure 3–3 displays the floorplan view in the Quartus II software.

Figure 3–2. Stratix & Stratix GX Architectural Elements *Note (1)*

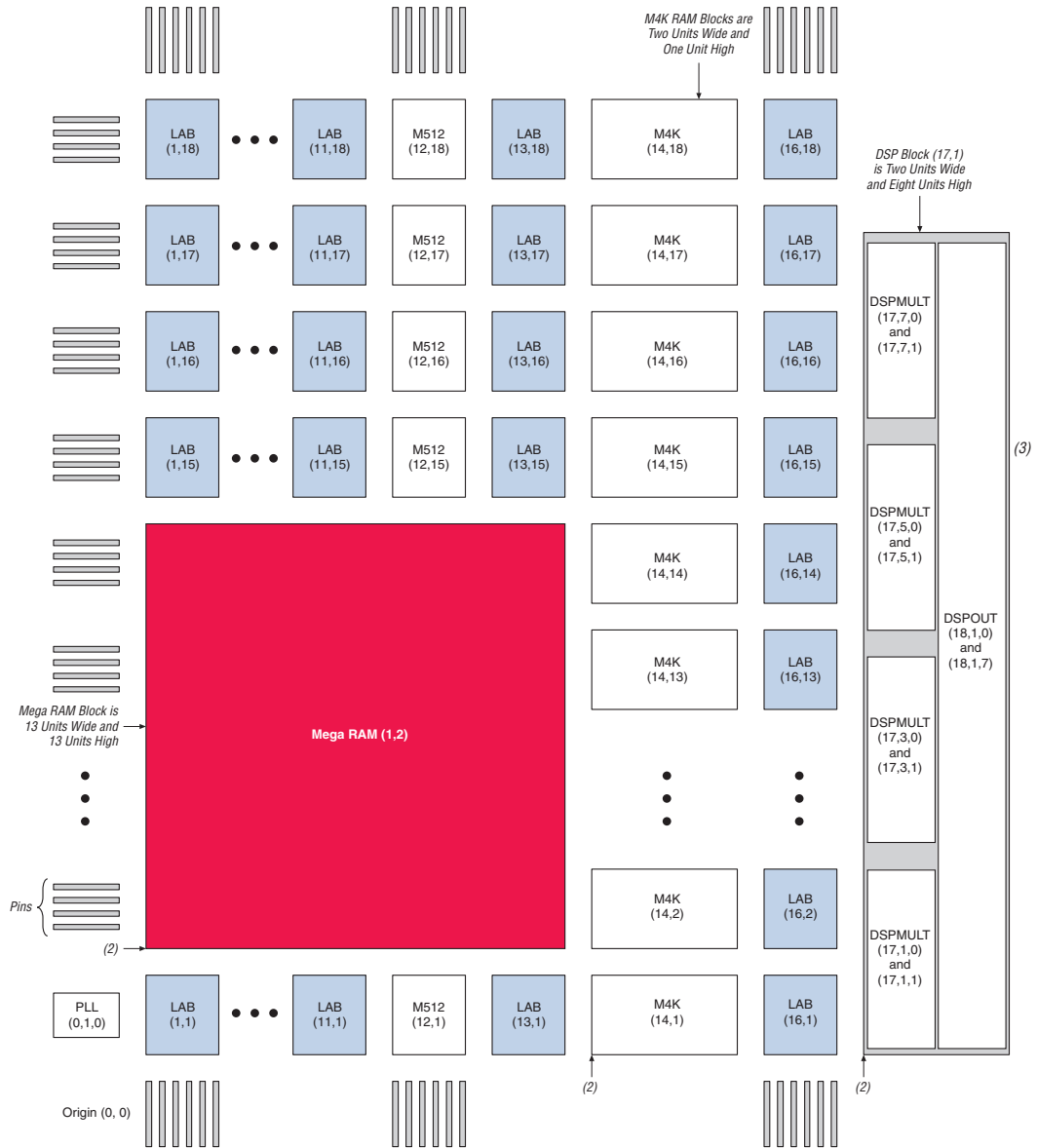

Notes to Figure 3–2:

- (1) Figure 3–2 shows part of a Stratix and Stratix GX device.
- (2) Large block elements use their lower-left corner for the coordinate location.
- (3) The Stratix GX architectural elements include transceiver blocks on the right side of the device.

Figure 3–3. LE Numbering as Shown in the Quartus II Software

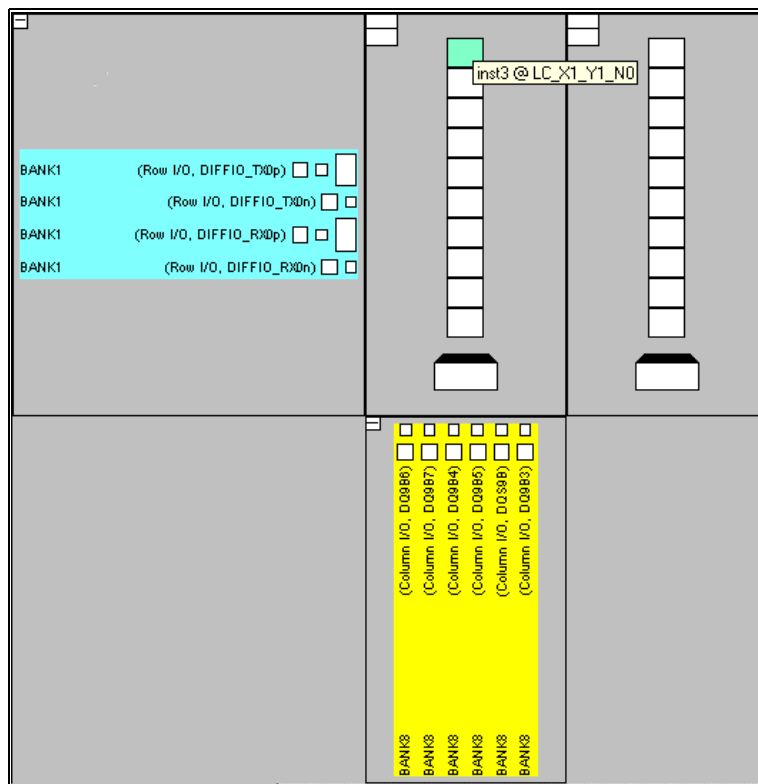

TriMatrix Memory

TriMatrix memory has three different sizes of memory blocks, each optimized for a different purpose or application. M512 blocks consist of 512 bits plus parity (576 bits), M4K blocks consist of 4K bits plus parity (4,608 bits), and M-RAM blocks consist of 512K bits plus parity (589,824 bits). This new structure differs from APEX II and APEX 20K devices, which feature uniformly sized embedded system blocks (ESBs) either 4 Kbits (APEX II devices) or 2 Kbits (APEX 20K devices) large. Stratix and Stratix GX TriMatrix memory blocks give you advanced control of each memory block, with features such as byte enables, parity bit storage, and shift-register mode, as well as mixed-port width support and true dual-port mode operation.

Table 3–4 compares TriMatrix memory with ESBs.

Features	Stratix & Stratix GX			APEX II ESB	APEX 20K ESB
	M512 RAM	M4K RAM	M-RAM		
Size (bits)	576	4,608	589,824	4,096	2,048
Parity bits	Yes	Yes	Yes	No	No
Byte enable	No	Yes	Yes	No	No
True dual-port mode	No	Yes Includes support for mixed width	Yes Includes support for mixed width	Yes Includes support for mixed width	No
Embedded shift register	Yes	Yes	No	No	No
Dedicated content-addressable memory (CAM) support	No	No	No	Yes	Yes
Pre-loadable initialization with a .mif (1)	Yes	Yes	No	Yes	Yes
Packed mode (2)	No	Yes	No	Yes	Yes
Feed-through behavior	Rising edge	Rising edge	Rising edge	Falling edge	Falling edge
Output power-up condition	Powers up cleared even if using a .mif (1)	Powers up cleared even if using a .mif (1)	Powers up with unknown state	Powers up cleared or to initialized value, if using a .mif (1)	Powers up cleared or to initialized value, if using a .mif (1)

Notes to Table 3–4:

- (1) **.mif**: Memory Initialization File.
- (2) Packed mode refers to combining two single-port RAM blocks into a single RAM block that is placed into true dual-port mode.

Stratix and Stratix GX TriMatrix memory blocks only support pipelined mode, while APEX II and APEX 20K ESBs support both pipelined and flow-through modes. Since all TriMatrix memory blocks can be pipelined, all input data and address lines are registered, while outputs can be either registered or combinatorial. You can use Stratix and Stratix GX memory block registers to implement input and output registers without utilizing additional resources. You can compile designs containing pipelined memory blocks (inputs registered) for Stratix and Stratix GX devices without any modifications. However, if an APEX II or

APEX 20K design contains flow-through memory, you must modify the memory modules to target the Stratix and Stratix GX architectures (see “Memory Megafunctions” on page 3–12 for more information).



For more information about TriMatrix memory and converting flow-through memory modules to pipelined, see the *TriMatrix Embedded Memory Blocks in Stratix & Stratix GX Devices* chapter in the *Stratix GX Device Handbook* and AN 210: *Converting Memory from Asynchronous to Synchronous for Stratix & Stratix GX Designs*.

Same-Port Read-During-Write Mode

In same-port read-during-write mode, the RAM block can be in single-port, simple dual-port, or true dual-port mode. One port from the RAM block both reads and writes to the same address location using the same clock. When APEX II or APEX 20K devices perform a same-port read-during-write operation, the new data is available on the falling edge of the clock cycle on which it was written, as shown in Figure 3–4. When Stratix and Stratix GX devices perform a same-port read-during-write operation, the new data is available on the rising edge of the same clock cycle on which it was written, as shown in Figure 3–5. This holds true for all TriMatrix memory blocks.

Figure 3–4. Falling Edge Feed-Through Behavior (APEX II & APEX 20K Devices) Note (1)

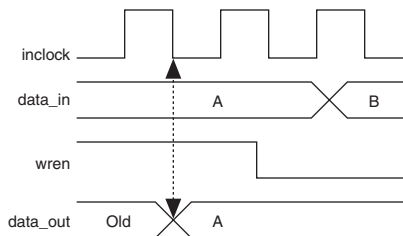

Note to Figure 3–4:

- (1) Figures 3–4 and 3–5 assume that the address stays constant throughout and that the outputs are not registered.

Figure 3–5. Rising Edge Feed-Through Behavior
 (Stratix & Stratix GX Devices) *Note (1)*

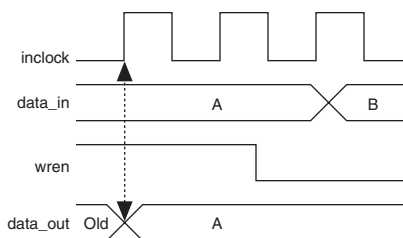

Note to Figure 3–5:

- (1) Figures 3–4 and 3–5 assume that the address stays constant throughout and that the outputs are not registered.

Mixed-Port Read-During-Write Mode

Mixed-port read-during-write mode occurs when a RAM block in simple or true dual-port mode has one port reading and the other port writing to the same address location using the same clock. In APEX II and APEX 20K designs, the ESB outputs the old data in the first half of the clock cycle and the new data in the second half of the clock cycle, as indicated by Figure 3–6.

Figure 3–6. Mixed-Port Feed-Through Behavior
 (APEX II & APEX 20K Devices) *Note (1)*

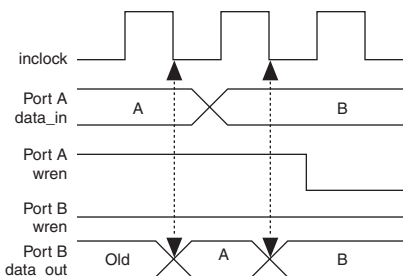

Note to Figure 3–6:

- (1) Figure 3–6 assumes that outputs are not registered.

Stratix and Stratix GX device RAM outputs the new data on the rising edge of the clock cycle immediately after the data was written. When you use Stratix and Stratix GX M512 and M4K blocks, you can choose whether to output the old data at the targeted address or output a don't care value during the clock cycle when the new data is written. M-RAM blocks

always output a don't care value. Figures 3-7 and 3-8 show the feed-through behavior of the mixed-port mode. You can use the `altsyncram` megafunction to set the output behavior during mixed-port read-during-write mode.

Figure 3-7. Mixed-Port Feed-Through Behavior (OLD_DATA) Note (1)

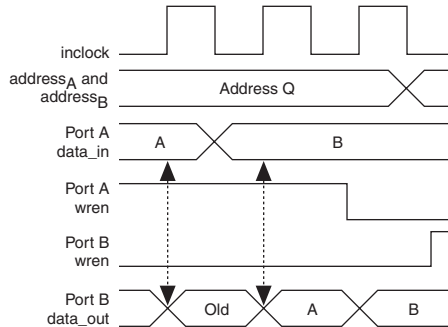

Note to Figure 3-7:

- (1) Figures 3-7 and 3-8 assume that the address stays constant throughout and that the outputs are not registered.

Figure 3-8. Mixed-Port Feed-Through Behavior (DONT_CARE) Note (1)

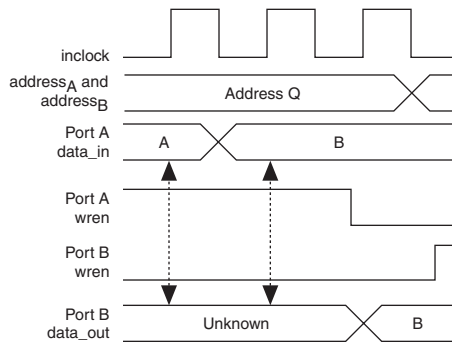

Note to Figure 3-8:

- (1) Figures 3-7 and 3-8 assume that the address stays constant throughout and that the outputs are not registered.

Memory Megafunctions

To convert RAM and ROM originally targeting the APEX II or APEX 20K architecture to Stratix or Stratix GX memory, specify Stratix or Stratix GX as the target family in the MegaWizard Plug-In Manager. The software

updates the memory module for the Stratix or Stratix GX architecture and instantiates the new synchronous memory megafunction, `altsyncram`, which supports both RAM and ROM blocks in the Stratix and Stratix GX architectures.

FIFO Conditions

First-in first-out (FIFO) functionality is slightly different in Stratix and Stratix GX devices compared to APEX II and APEX 20K devices. Stratix and Stratix GX devices do not support simultaneous reads and writes from an empty FIFO buffer. Also, Stratix and Stratix GX devices do not support the `lpm_showahead` parameter when targeting a FIFO buffer because the TriMatrix memory blocks are synchronous. The `lpm_showahead` parameter for APEX II and APEX 20K devices puts the FIFO buffer in “read-acknowledge” mode so the first data written into the FIFO buffer immediately flows through to the output. Other than these two differences, all APEX II and APEX 20K FIFO functions are fully compatible with the Stratix and Stratix GX architectures.

Design Migration Mode in Quartus II Software

The Quartus II software features a migration mode for simplifying the process of converting APEX II and APEX 20K memory functions to the Stratix or Stratix GX architecture. If the design can use the Stratix or Stratix GX `altsyncram` megafunction as a replacement for a previous APEX II or APEX 20K memory function while maintaining functionally similar behavior, the Quartus II software automatically converts the memory. The software produces a warning message during compilation reminding you to verify that the design migrated correctly.

For memory blocks with all inputs registered, the existing megafunction is converted to the new `altsyncram` megafunction. The software generates a warning when the `altsyncram` megafunction is incompatible. For example, a RAM block with all inputs registered except the read enable compiles with a warning message indicating that the read-enable port is registered.

You can suppress warning messages for the entire project or for individual memory blocks by setting the `SUPPRESS_MEMORY_CONVERSION_WARNINGS` parameter to “on” as a global parameter by selecting **Assignment Organizer** (Tools menu). In the **Assignment Organizer** window, click **Parameters** in the **Assignment Categories** box. Type `SUPPRESS_MEMORY_CONVERSION_WARNINGS` in the **Assignment Name** box and type ON in the **Assignment Setting** box. To suppress these warning messages on a per-memory-instance basis, set the `SUPPRESS_MEMORY_CONVERSION_WARNINGS` parameter in the Assignment Organizer to “on” for the memory instance.

If the functionality of the APEX II or APEX 20K memory megafunction differs from the `altsyncram` functionality and at least one clock feeds the memory megafunction, the Quartus II software converts the APEX II or APEX 20K memory megafunction to the Stratix or Stratix GX `altsyncram` megafunction. This conversion is useful for an initial evaluation of how a design might perform in Stratix or Stratix GX devices and should only be used for evaluation purposes. During this process, the Quartus II software generates a warning that the conversion may be functionally incorrect and timing results may not be accurate. Since the functionality may be incorrect and the compilation is only intended for comparative purposes, the Quartus II software does not generate a programming file. A functionally correct conversion requires manually instantiating the `altsyncram` megafunction and may require additional design changes.

If the previous memory function does not have a clock (fully asynchronous), the fitting-evaluation conversion results in an error message during compilation and does not successfully convert the design.



See *AN 210: Converting Memory from Asynchronous to Synchronous for Stratix & Stratix GX Designs* for more information.

Table 3-5 summarizes the possible scenarios when using design migration mode and the resulting behavior of the Quartus II software.

The most common cases where design-migration mode may have difficulty converting the existing design are when:

- A port is reading from an address that is being written to by another port (mixed-port read-during-write mode). If both ports are using the same clock, the read port in Stratix and Stratix GX devices do not see the new data until the next clock cycle, after the new data was written.

- There are differences in power-up behavior between APEX II, APEX 20K, and Stratix and Stratix GX devices. You should manually account for these differences to maintain desired operation of the system.

Table 3–5. Migration Mode Summary

Memory Configuration	Conditions	Possible Instantiated Megafunctions	Quartus II Warning Message(s)	Programming File Generated
Single-port	All inputs are registered.	altram altrom lpm_ram_dq lpm_ram_io lpm_rom	Power-up differences. (1)	Yes
Multi-port (two-, three-, or four-port functions)	All inputs are registered.	altdpram lpm_ram_dp altqpram alt3pram	Power-up differences. Mixed-port read- during-write. (1)	Yes
Dual-port	Read-enable ports are unregistered. Other inputs registered.	altdpram lpm_ram_dp altqpram alt3pram	Power-up differences. Mixed-port read- during-write. Read enable will be registered. (1)	Yes
Dual-port	Any other unregistered port except read-enable ports. Clock available.	altdpram lpm_ram_dp altqpram alt3pram	Compile for fitting- evaluation purposes.	No
Single-port	At least one registered input. Clock available.	altram lpm_ram_dq lpm_ram_io	Compile for fitting- evaluation purposes.	No
No clock	No clock.	altram altrom altdpram altqpram alt3pram altdpram lpm_ram_dq lpm_ram_io lpm_rom lpm_ram_dp lpm_ram_dp	Error – no conversion possible.	No

Note to Table 3–5:

(1) If the SUPPRESS_MEMORY_CONVERSION_WARNINGS parameter is turned on, the Quartus II software does not issue these warnings.

DSP Block

Stratix and Stratix GX device DSP blocks outperform LE-based implementations for common DSP functions. Each DSP block contains several multipliers that can be configured for widths of 9, 18, or 36 bits. Depending on the mode of operation, these multipliers can optionally feed an adder/subtractor/accumulator or summation unit.

You can configure the DSP block's input registers to efficiently implement shift registers for serial input sharing, eliminating the need for external shift registers in LEs. You can add pipeline registers to the DSP block for accelerated operation. Registers are available at the input and output of the multiplier, and at the output of the adder/subtractor/accumulator or summation block.

DSP blocks have four modes of operation:

- Simple multiplier mode
- Multiply-accumulator mode
- Two-multipliers adder mode
- Four-multipliers adder mode

Associated megafunctions are available in the Quartus II software to implement each mode of the DSP block.

DSP Block Megafunctions

You can use the `lpm_mult` megafunction to configure the DSP block for simple multiplier mode. You can set the `lpm_mult` **Multiplier Implementation** option in the MegaWizard Plug-In Manager to either use the default implementation, ESBs, or the DSP blocks. If you select the **Use Default** option, the compiler first attempts to place the multiplier in the DSP blocks. However, under certain conditions, the compiler may implement the multiplier in LEs. The placement depends on factors such as DSP block resource consumption, the width of the multiplier, whether an operand is a constant, and other options chosen for the megafunction.

Stratix and Stratix GX devices do not support the **Use ESBs** option. If you select this option, the Quartus II software tries to place the multiplier in unused DSP blocks.

You can recompile APEX II or APEX 20K designs using the `lpm_mult` megafunction for Stratix and Stratix GX devices in the Quartus II software without changing the megafunction. This makes converting `lpm_mult` megafunction designs to Stratix or Stratix GX devices straightforward.

APEX II and APEX 20K designs use pipeline stages to improve registered performance of LE-based multipliers at the expense of latency. However, you may not need to use pipeline stages when targeting Stratix and Stratix GX high-speed DSP blocks. The DSP blocks offer three sets of dedicated pipeline registers. Therefore, Altera recommends that you reduce the number of pipeline stages to three or fewer and implement them in the DSP blocks. Additional pipeline stages are implemented in LEs, which add latency without providing any performance benefit.

For example, you can configure a DSP block for 36×36 -bit multiplication using the `lpm_mult` megafunction. If you specify two pipeline stages, the software uses the DSP block input and pipeline registers. If you specify three pipeline stages, the software places the third pipeline stage in the DSP block output registers. This design yields the same performance with three pipeline stages because the critical path for a 36×36 -bit operation is within the multiplier. With four or more pipeline stages, the device inefficiently uses LE resources for the additional pipeline stages. Therefore, if multiplier modules in APEX II or APEX 20K designs are converted to Stratix or Stratix GX designs and do not require the same number of pipeline stages, the surrounding circuitry must be modified to preserve the original functionality of the design.

A design with multipliers feeding an accumulator can use the `altmult_accum (MAC)` megafunction to set the DSP block in multiply-accumulator mode. If the APEX II or APEX 20K design already uses LE-based multipliers feeding an accumulator, the Quartus II software does not automatically instantiate the new `altmult_accum (MAC)` megafunction. Therefore, you should use the MegaWizard Plug-In Manager to instantiate the `altmult_accum (MAC)` megafunction. You can also use LeonardoSpectrum™ or Synplify synthesis tools, which have DSP block inference support, to instantiate the megafunction.

Designs that use multipliers feeding into adders can instantiate the new `altmult_add` megafunction to configure the DSP blocks for two-multipliers adder or four-multipliers adder mode. You can also use the `altmult_add` megafunction for stand-alone multipliers to take advantage of the DSP blocks features such as dynamic sign control of the inputs and the input shift register connections. These features are not accessible through the `lpm_mult` megafunction. If your APEX II or APEX 20K designs already use multipliers feeding an adder/subtractor, the Quartus II software does not automatically infer the new `altmult_add` megafunction. Therefore, you should step through the MegaWizard Plug-In Manager to instantiate the new `altmult_add` megafunction or use LeonardoSpectrum or Synplify synthesis tools, which have DSP block inference support.

Furthermore, the `altmult_add` and `altmult_accum` (MAC) megafunctions are only available for Stratix and Stratix GX devices because these megafunctions target Stratix and Stratix GX DSP blocks, which are not available in other device families. If you attempt to use these megafunctions in designs that target other Altera device families, the Quartus II software reports an error message. Use `lpm_mult` and an `lpm_add_sub` or an `altaccumulate` megafunction for similar functionality in other device families.

If you use a third-party synthesis tool, you may be able to avoid the megafunction conversion process. LeonardoSpectrum and Synplify provide inference support for `lpm_mult`, `altmult_add`, and `altmult_accum` (MAC) to use the DSP blocks.

If your design does not require you to implement all the multipliers in DSP blocks, you must manually set a global parameter or a parameter for each instance to force the tool to implement the `lpm_mult` megafunction in LEs. Depending on the synthesis tools, inference of DSP blocks is handled differently.



For more information about using DSP blocks in Stratix and Stratix GX devices, see the *DSP Blocks in Stratix & Stratix GX Devices* chapter of the *Stratix Device Handbook*.

PLLs & Clock Networks

Stratix and Stratix GX devices provide exceptional clock management with a hierarchical clock network and up to four enhanced phase-locked loops (PLLs) and eight fast PLLs versus the four general-purpose PLLs and four True-LVDS™ PLLs in APEX II devices. By providing superior clock interfacing, numerous advanced clocking features, and significant enhancements over APEX II and APEX 20K PLLs, the Stratix and Stratix GX device PLLs increase system performance and bandwidth.

Clock Networks

There are 16 global clock networks available throughout each Stratix or Stratix GX device as well as two fast regional and four regional clock networks per device quadrant, resulting in up to 40 unique clock networks per device. The increased number of dedicated clock resources available in Stratix and Stratix GX devices eliminate the need to use general-purpose I/O pins as clock inputs.

Stratix EP1S25 and smaller devices have 16 dedicated clock pins and EP1S30 and larger devices have four additional clock pins to feed various clocking networks. In comparison, APEX II devices have eight dedicated clock pins and APEX 20KE and APEX 20KC devices have four dedicated clock pins.

The dedicated clock pins in Stratix and Stratix GX devices can feed the PLL clock inputs, the global clock networks, and the regional clock networks. PLL outputs and internally-generated signals can also drive the global clock network. These global clocks are available throughout the entire device to clock all device resources.

Stratix and Stratix GX devices are divided into four quadrants, each equipped with four regional clock networks. The regional clock network can be fed by either the dedicated clock pins or the PLL outputs within its device quadrant. The regional clock network can only feed device resources within its particular device quadrant.

Each Stratix and Stratix GX device provides eight dedicated fast clock I/O pins $FCLK[7..0]$ versus four dedicated fast I/O pins in APEX II and APEX 20K devices. The fast regional clock network can be fed by these dedicated $FCLK[7..0]$ pins or by the I/O interconnect. The I/O interconnect allows internal logic or any I/O pin to drive the fast regional clock network. The fast regional clock network is available for general-purpose clocking as well as high fan-out control signals such as clear, preset, enable, $TRDY$ and $IRDY$ for PCI applications, or bidirectional or output pins.

EP1S25 and smaller devices have eight fast regional clock networks, two per device quadrant. The quadrants in EP1S30 and larger devices are divided in half, and each half-quadrant can be clocked by one of the eight fast regional networks. Additionally, each fast regional clock network can drive its neighboring half-quadrant (within the same device quadrant).

PLLs

Table 3–6 highlights Stratix and Stratix GX PLL enhancements to existing APEX II, APEX 20KE and APEX 20KC PLL features.

Feature	Stratix & Stratix GX		APEX II PLLs	APEX 20KE & APEX 20KC PLLs
	Enhanced PLLs	Fast PLLs		
Number of PLLs	Two (EP1S30 and smaller devices); four (EP1S40 and larger devices) (9)	Four (EP1S25 and smaller devices); eight (EP1S30 and larger devices) (10)	Four general-purpose PLLs and four LVDS PLLs	Up to four general-purpose PLLs. Up to two LVDS PLLs. (1)
Minimum input frequency	3 MHz	15 MHz	1.5 MHz	1.5 MHz
Maximum input frequency	250 to 582 MHz (2)	644.5 MHz (11)	420 MHz	420 MHz

Table 3–6. Stratix & Stratix GX PLL vs. APEX II, APEX 20KE & APEX 20KC PLL Features (Part 2 of 2)

Feature	Stratix & Stratix GX		APEX II PLLs	APEX 20KE & APEX 20KC PLLs
	Enhanced PLLs	Fast PLLs		
Internal clock outputs per PLL	6	3 (3)	2	2
External clock outputs per PLL	Four differential/eight singled-ended or one single-ended (4)	Yes (5)	1	1
Phase Shift	Down to 160-ps increments (6)	Down to 125-ps increments (6)	500-ps to 1-ns resolution	0.4- to 1-ns resolution
Time shift	250-ps increments for ± 3 ns (7)	No	No	No
M counter values	1 to 512	1 to 32	1 to 160	2 to 160
N counter values	1 to 512	N/A	1 to 16	1 to 16
PLL clock input sharing	No	Yes	Yes	Yes
T1/E1 rate conversion (8)	No	No	Yes	Yes

Notes to Table 3–6:

- (1) EP20K200E and smaller devices only have two general-purpose PLLs. EP20K400E and larger devices have two LVDS PLLs and four general-purpose PLLs. For more information, see *AN 115: Using the ClockLock & ClockBoost PLL Features in APEX Devices*.
- (2) The maximum input frequency for Stratix and Stratix GX enhanced PLLs depends on the I/O standard used with that input clock pin. For more information, see the *Stratix Device Family Data Sheet* section of the *Stratix Device Handbook, Volume 1* or the *Stratix GX Device Family Data Sheet* section of the *Stratix GX Device Handbook*.
- (3) Fast PLLs 1, 2, 3, and 4 have three internal clock output ports per PLL. Fast PLLs 7, 8, 9, and 10 have two internal clock output ports per PLL.
- (4) Every Stratix device has two enhanced PLLs with eight single-ended or four differential outputs each. Two additional enhanced PLLs in EP1S80, EP1S60, and EP1S40 devices each have one single-ended output.
- (5) Any I/O pin can be driven by the fast PLL global or regional outputs as an external clock output pin.
- (6) The smallest phase shift unit is determined by the voltage-controlled oscillator (VCO) period divided by 8.
- (7) There is a maximum of 3 ns between any two PLL clock outputs.
- (8) The T1 clock frequency is 1.544 MHz and the E1 clock frequency is 2.048 MHz, which violates the minimum clock input frequency requirement of the Stratix PLL.
- (9) Stratix GX EP1SGX10 and EP1SGX25 contain two. EP1SGX40 contains four.
- (10) Stratix GX EP1SGX10 and EP1SGX25 contain two. EP1SGX40 contains four.
- (11) Stratix GX supports clock rates of 1 Gbps using DPA.

Enhanced PLLs

Stratix and Stratix GX devices provide up to four enhanced PLLs with advanced PLL features. In addition to the feature changes mentioned in [Table 3–6](#), Stratix and Stratix GX device PLLs include many new,

advanced features to improve system timing management and performance. Table 3-7 shows some of the new features available in Stratix and Stratix GX enhanced PLLs.

Feature	Description
Programmable duty cycle (1)	Allows variable duty cycle for each PLL clock output.
PLL clock outputs can feed logic array (1)	Allows the PLL clock outputs to feed data ports of registers or combinatorial logic.
PLL locked output can feed the logic array (1)	Allows the PLL locked port to feed data ports of registers or combinatorial logic.
Multiplication allowed in zero-delay buffer mode or external feedback mode	The PLL clock outputs can be a multiplied or divided down ratio of the PLL input clock.
Programmable phase shift allowed in zero-delay buffer mode or external feedback mode (2)	The PLL clock outputs can be phase shifted. The phase shift is relative to the PLL clock output.
Phase frequency detector (PFD) disable	Allows the VCO to operate at its last set control voltage and frequency with some long term drift.
Clock output disable (3)	PLL maintains lock with output clocks disabled. (4)
Programmable lock detect & gated lock	Holds the lock signal low for a programmable number of input clock cycles.
Dynamic clock switchover	Enables the PLL to switch between two reference input clocks, either for clock redundancy or dual-clock domain applications.
PLL reconfiguration	Allows the counters and delay elements within the PLL to be reconfigured in real-time without reloading a programmer object file (.pof).
Programmable bandwidth	Provides advanced control of the PLL bandwidth by using the programmable control of the PLL loop characteristics.
Spread spectrum	Modulates the target frequency over a frequency range to reduce electromagnetic interference (EMI) emissions.

Notes to Table 3-7:

- (1) These features are also available in fast PLLs.
- (2) In addition to the delay chains at each counter, you can specify the programmable phase shift for each PLL output at fine and coarse levels.
- (3) Each PLL clock output has an associated clock enable signal.
- (4) If the PLL is used in external feedback mode, the PLL will need to reload.

Fast PLLs

Stratix and Stratix GX fast PLLs are similar to the APEX II True-LVDS PLLs in that the *W* setting, which governs the relationship between the clock input and the data rate, and the *J* setting, which controls the width

of the high-speed differential I/O data bus, do not have to be equal. Additionally, Stratix and Stratix GX fast PLLs offer up to three clock outputs, two multiplied high-speed PLL clocks to drive the serializer/deserializer (SERDES) block and/or an external pin, and a low-speed clock to drive the logic array. You can use fast PLLs for both high-speed interfacing and for general-purpose PLL applications.

Table 3–8 shows the differences between Stratix and Stratix GX fast PLLs and APEX II and APEX 20K True-LVDS PLLs.

Feature	Stratix & Stratix GX	APEX II	APEX 20KE APEX 20KC
Number of fast PLLs or True-LVDS PLLs (1)	Four (EP1S25 and smaller devices) fast PLLs Eight (EP1S30 and larger devices) fast PLLs (4)	Four True-LVDS PLLs	Two True-LVDS PLLs (2)
Number of channels per transmitter/receiver block	20	18	18
VCO frequency	300 to 840 MHz (5)	200 MHz to 1GHz	200 to 840 MHz
Minimum input frequency $M = 4, 5, 6$	$300 - M$ MHz	50 MHz	50 MHz $M = 4$ (3)
Minimum input frequency $M = 7, 8, 9, 10$	$300 - M$ MHz	30 MHz	30 MHz $M = 7, 8$ (3)

Notes to Table 3–8:

- (1) You can also use Stratix and Stratix GX device fast PLLs for general-purpose PLL applications.
- (2) EP20K400E and larger devices have two True-LVDS PLLs.
- (3) In APEX 20KE and APEX 20KC devices, $M = 4, 7, \text{ or } 8$.
- (4) Stratix GX EP1SGX10 and EP1SGX25 contain two. EP1SGX10 contains four.
- (5) Stratix GX supports a frequency range of 300–1000 MHz (using DPA).

The Stratix and Stratix GX fast PLL VCO frequency range is 300 to 840 MHz, and the APEX II True-LVDS PLL VCO frequency range is 200 MHz to 1 GHz. Therefore, you must update designs that use a data rate of less than 300 megabits per second (Mbps) to use the enhanced PLLs and M512 RAM blocks in SERDES bypass mode. Additionally, you must update designs that use a data rate faster than 840 Mbps.

altpll Megafunction

Altera recommends that you replace instances of the `altclklock` megafunction with the `altpll` megafunction to take advantage of new Stratix and Stratix GX PLL features. Although in most cases you can retarget your APEX II or APEX 20K design to a Stratix or Stratix GX

device with the `altclklock` megafunction, there are specific cases where you must use the `altpll` megafunction, as explained in this section.

In the MegaWizard Plug-In Manager, select the `altpll` megafunction in the I/O directory from the **Available Megafunctions** box (see [Figure 3-9](#)). The `altclklock` megafunction is also available from the Quartus II software for backward compatibility, but instantiates the new `altpll` megafunction when targeting Stratix or Stratix GX devices. The Quartus II Compiler automatically selects whether the `altpll` module uses either an enhanced PLL or a fast PLL based on the design's PLL needs and the feature requirements of each PLL.

Figure 3-9. altpll Megafunction Selection in the MegaWizard Plug-In Manager

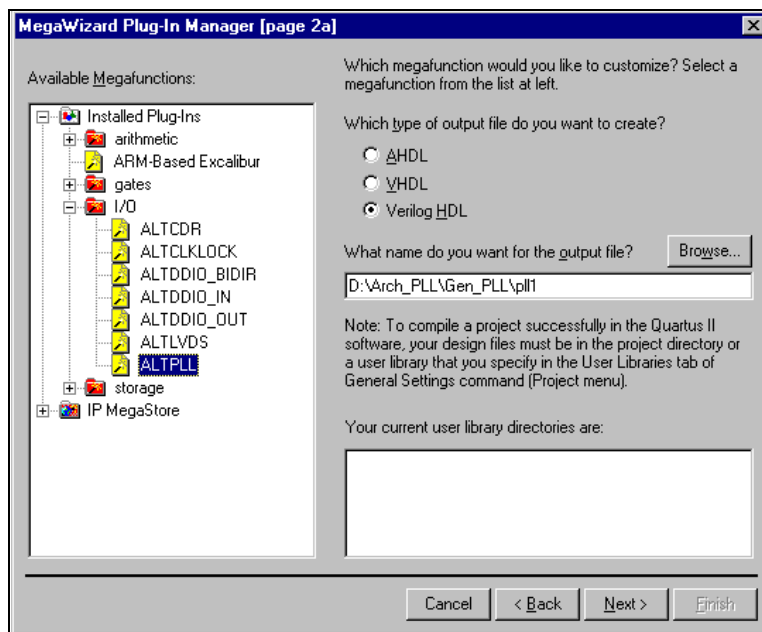

You can compile APEX II, APEX 20KE, and APEX 20KC designs using the `altclklock` megafunction in normal mode for Stratix and Stratix GX devices without updating the megafunction. However, you should replace the `altclklock` megafunction with the `altpll` megafunction. If the Quartus II software cannot implement the requested clock multiplication and division of the PLL, the compiler reports an error message with the appropriate reason stated.

APEX II, APEX 20KE, and APEX 20KC devices have only one external clock output available per PLL. Therefore, when retargeting an APEX II, APEX 20KE, or APEX 20KC design that uses PLLs in zero delay buffer mode or external feedback mode to a Stratix or Stratix GX device, you should replace instances of the `altclklock` megafunction. If an APEX II, APEX 20KE, or APEX 20KC `altclklock` module only uses one PLL clock output (internal or external) and is compiled to target a Stratix or Stratix GX device, the design compiles successfully with a warning that the design uses the Stratix or Stratix GX PLL external clock output, `extclk0`. However, if the APEX II, APEX 20KE, or APEX 20KC PLL has more than one PLL clock output, you must replace instances of the `altclklock` megafunction with the `altpll` megafunction because the Quartus II Compiler does not know which PLL clock output is fed to an external output pin or fed back to the Stratix or Stratix GX device `fb` pin. For example, if an APEX II, APEX 20KE, or APEX 20KC design with an `altclklock` megafunction uses the `clock0` output port to feed the external clock output pin and the `clock1` output port to feed the internal logic array, the Quartus II software generates an error during compilation and you must use the MegaWizard Plug-In Manager to instantiate the `altpll` megafunction. By using the `altpll` megafunction, you can choose which of the four external clock outputs to use and take advantage of the new Stratix and Stratix GX PLL features now available in the zero delay buffer mode or external feedback mode.

Timing Analysis

When the Quartus II software performs a timing analysis for APEX II, APEX 20KE, or APEX 20KC designs, PLL clock settings override the project clock settings. However, during timing analysis for Stratix and Stratix GX designs using PLLs, the project clock settings override the PLL input clock frequency and duty cycle settings. The MegaWizard Plug-In Manager does not use the project clock settings to determine the `altpll` parameters. This saves time with designs that use features such as clock switchover or PLL reconfiguration because the Quartus II software can perform a timing analysis without recompiling the design. It is important to note the following:

- A warning during compilation reports that the project clock settings overrides the PLL clock settings.
- The project clock setting overrides the PLL clock settings for timing-driven compilation.
- The compiler will check the lock frequency range of the PLL. If the frequency specified in the project clock settings is outside the lock frequency range, the PLL clock settings will not be overridden.
- Performing a timing analysis without recompiling your design does not change the programming files. You must recompile your design to update the programming files.

- A **Default Required** f_{MAX} setting does not override the PLL clock settings. Only individual clock settings override the PLL clock settings.

Therefore, you can enter different project clock settings corresponding to new PLL settings and accelerate timing analysis by eliminating a full compilation cycle.



For more information about using Stratix and Stratix GX PLLs, see the *General-Purpose PLLs in Stratix & Stratix GX Devices* chapter.

I/O Structure

The Stratix and Stratix GX I/O element (IOE) architecture is similar to the APEX II architecture, with a total of six registers and a latch in each IOE. The registers are organized in three sets: two output registers to drive a single or double-data rate (DDR) output path, two input registers and a latch to support a single or DDR input path, and two output enable registers to enhance clock-to-output enable timing or for DDR SDRAM interfacing. A new synchronous reset signal is available to each of the three sets of registers for preset or clear, or neither. In addition to the advanced IOE architecture, the Stratix and Stratix GX IOE features dedicated circuitry for external RAM interfacing, new I/O standards, differential on-chip termination, and high-speed differential I/O standard support.

External RAM Interfacing

The advanced Stratix and Stratix GX IOE architecture includes dedicated circuitry to interface with external RAM. This circuitry provides enhanced support for external high-speed memory devices such as DDR SDRAM and FCRAM. The DDR SDRAM interface uses a bidirectional signal, DQS , to clock data, DQ , at both the transmitting and receiving device. Stratix and Stratix GX devices transmit the DQS signal with the DQ data signals to minimize clock to data skew.

Stratix and Stratix GX devices include groups of programmable DQS and DQ pins, in the top and bottom I/O banks of the device. Each group consists of a DQS pin that supports a fixed number of DQ pins. The number of DQ pins depends on the DQ bus mode. When using the external RAM interfacing circuitry, the DQS pin drives a dedicated clock network that feeds the DQ pins residing in that bank. The Stratix and Stratix GX IOE has programmable delay chains that can phase shift the DQS signal by 90° or 72° to ensure data is sampled at the appropriate point in time. Therefore, the Stratix and Stratix GX devices make full use of the IOEs, and remove the need to build the input data path in the logic array. You can make these I/O assignments in the Quartus II Assignment Organizer.



For more information on external RAM interfacing, see the *Stratix Device Family Data Sheet* section of the *Stratix Device Handbook, Volume 1* or the *Stratix GX Device Family Data Sheet* in the *Stratix GX Device Family Handbook*.

I/O Standard Support

The Stratix and Stratix GX devices support all of the I/O standards that APEX II and APEX 20K devices support, including high-speed differential I/O standards such as LVDS, LVPECL, PCML, and HyperTransport™ technology, differential HSTL on input and output clocks, and differential SSTL on output clocks. Stratix and Stratix GX devices also introduce support for SSTL-18 class I & II. Similar to APEX II devices, Stratix and Stratix GX devices only support certain I/O standards in designated I/O banks. In addition, `vref` pins are dedicated pins in Stratix and Stratix GX devices and now support up to 40 input pins.



For more information about I/O standard support in Stratix and Stratix GX devices, see the *Selectable I/O Standards in Stratix & Stratix GX Devices* chapter.

High-Speed Differential I/O Standards

Stratix and Stratix GX devices support high-speed differential interfaces at speeds up to 840 Mbps using high-speed PLLs that drive a dedicated clock network to the SERDES. Each fast PLL can drive up to 20 high-speed channels. Stratix and Stratix GX devices use enhanced PLLs and M512 RAM blocks to provide up to 420 Mbps performance for SERDES bypass clock interfacing. There is no restriction on the number of channels that can be clocked using this scenario.

Stratix and Stratix GX devices have a different number of differential channels than APEX II devices. [Tables 3–9](#) and [3–10](#) highlight the number of differential channels supported in Stratix and Stratix GX devices.

Table 3–9. Number of Dedicated Differential Channels in Stratix Devices
(Part 1 of 2) *Note (1)*

Device	Pin Count	Number of Receiver Channels	Number of Transmitter Channels
EP1S10	672	36	36
	780	44	44
EP1S20	672	50	48
	780	66	66

Table 3–9. Number of Dedicated Differential Channels in Stratix Devices (Part 2 of 2) Note (1)

Device	Pin Count	Number of Receiver Channels	Number of Transmitter Channels
EP1S25	672	58	56
	780	66	70
	1,020	78	78
EP1S30	780	66	70
	956	80	80
	1,020	80	80
		2	2
EP1S40	956	80	80
	1,020	80	80
		10	10
	1,508	80	80
		10	10
EP1S60	956	80	80
	1,020	80	80
		10	12
	1,508	80	80
		36	36
EP1S80	956	80	80
		0	40
	1,508	80	80
		56	72

Note to Table 3–9:

- (1) For information on channel speeds, see the *Stratix Device Family Data Sheet* section of the *Stratix Device Handbook, Volume 1* and the *High-Speed Differential I/O Interfaces* chapter in the *Stratix Device Handbook, Volume 2*.

Table 3–10. Number of Dedicated Differential Channels in Stratix GX Devices (Part 1 of 2) Note (1)

Device	Pin Count	Number of Transceivers	Number of Source-Synchronous Channels
EP1SGX10 C	672	4	22
EP1SGX10 D	672	8	22

Table 3–10. Number of Dedicated Differential Channels in Stratix GX Devices (Part 2 of 2) *Note (1)*

Device	Pin Count	Number of Transceivers	Number of Source-Synchronous Channels
EP1SGX25 C	672	4	39
EP1SGX25 D	672/1,020	8	39
EP1SGX25 F	1,020	16	39
EP1SGX40 D	1,020	8	45
EP1SGX40 G	1,020	20	45

Note to Table 3–10:

- (1) For information on channel speeds, see the *Stratix GX Device Family Data Sheet* section of the *Stratix GX Device Handbook, Volume 1* and the *High-Speed Source-Synchronous Differential I/O Interfaces in Stratix GX Devices* chapter of the *Stratix GX Device Handbook, Volume 2*.

The differential I/O within Stratix GX also provides dynamic phase alignment (DPA). DPA enables the differential I/O to operate up to 1 Gbps per channel. DPA automatically and continuously tracks fluctuations caused by system variations and self-adjusts to eliminate the phase skew between the multiplied clock and the serial data. The block contains a dynamic phase selector for phase detection and selection, a SERDES, a synchronizer, and a data realigner circuit. You can bypass the dynamic phase aligner without affecting the basic source-synchronous operation of the channel by using a separate deserializer.

If you compile an APEX II LVDS design that uses clock-data synchronization (CDS) for a Stratix or Stratix GX device, the Quartus II software issues a warning during compilation that Stratix and Stratix GX devices do not support CDS.

Stratix and Stratix GX devices offer a flexible solution using new byte realignment circuitry to correct for byte misalignment by shifting, or slipping, data bits. Stratix and Stratix GX devices activate the byte realignment circuitry when an external pin (`rx_data_align`) or an internal custom-made state machine asserts the `SYNC` node high.

APEX II, APEX 20KE, and APEX 20KC devices have a dedicated transmitter clock output pin (`LVDSTXOUTCLK`). In Stratix and Stratix GX devices, a transmitter `dataout` channel with an LVDS clock (fast clock) generates the transmitter clock output. Therefore, you can drive any channel as an output clock to an I/O pin, not just dedicated clock output pins. This solution offers better versatility to address various applications that require more complex clocking schemes.



For more information on differential I/O support, data realignment, and the transmitter clock output in Stratix and Stratix GX devices, see the *High-Speed Differential I/O Interfaces in Stratix Devices* chapter.

altlvds Megafunction

To take full advantage of the high-speed differential I/O standards available in Stratix and Stratix GX devices, you should update each instance of the `altlvds` megafunction in APEX II, APEX 20KE, and APEX 20KC designs. In the MegaWizard Plug-In Manager, choose the `altlvds` megafunction, select Stratix or Stratix GX as the target device family, update the megafunction, and recompile your design.

The `altlvds` megafunction supports new Stratix and Stratix GX parameters that are not available for APEX II, APEX 20KE, and APEX 20KC devices. Tables 3–11 and 3–12 describe the new parameters for the LVDS receiver and LVDS transmitter, respectively.

Table 3–11. New altlvds Parameters for Stratix LVDS Receiver *Note (1)*

Parameter	Function
<code>input_data_rate</code> (2)	Specifies the data rate in Mbps. This parameter replaces the multiplication factor <i>W</i> .
<code>inclock_data_alignment</code>	Indicates the alignment of <code>rx_inclk</code> and <code>rx_in</code> data.
<code>rx_data_align</code>	Drives the data alignment port of the fast PLL and enables byte realignment circuitry.
<code>registered_data_align_input</code>	Registers the <code>rx_data_align</code> input port to be clocked by <code>rx_outclock</code> .
<code>common_rx_tx_pll</code> (3)	Indicates the fast PLL can be shared between receiver and transmitter applications.

Table 3–12. New altlvds Parameters for Stratix LVDS Transmitter (Part 1 of 2) *Note (1)*

Parameter	Function
<code>output_data_rate</code> (2)	Specifies the data rate in Mbps. This parameter replaces the multiplication factor <i>W</i> .
<code>inclock_data_alignment</code>	Indicates the alignment of <code>tx_inclk</code> and <code>tx_in</code> data.
<code>outclock_alignment</code>	Specifies the alignment of <code>tx_outclock</code> and <code>tx_out</code> data.
<code>registered_input</code>	Specifies the clock source for the input synchronization registers, which can be either <code>tx_inclock</code> or <code>tx_coreclock</code> . Used only when the Registered Inputs option is selected.

Table 3–12. New altlvds Parameters for Stratix LVDS Transmitter (Part 2 of 2) Note (1)

Parameter	Function
common_rx_tx_pll (3)	Indicates the fast PLL can be shared between receiver and transmitter applications.

Notes to Tables 3–11 and 3–12:

- (1) You can specify these parameters in the MegaWizard Plug-In Manager.
- (2) You must specify a data rate in the MegaWizard Plug-In Manager instead of a W factor.
- (3) The same fast PLL can be used to clock both the receiver and transmitter only if both are running at the same frequency.

Above the standard I/O offered by APEX II, APEX 20K, and Stratix devices, Stratix GX devices provide up to 20 3.175 Gbps transceivers. The transceivers provide high-speed serial links for chip-to-chip, backplane, and line-side connectivity and support a number of the emerging high-speed protocols. You can find more information in the *Stratix GX Family Data Sheet* in the *Stratix GX Family Handbook, Volume 1*.

Configuration

The Stratix and Stratix GX devices supports all current configuration schemes, including the use of enhanced configuration devices, passive serial (PS), passive parallel asynchronous (PPA), fast passive parallel (FPP), and JTAG. Stratix and Stratix GX devices also provide a number of new configuration enhancements that you can take advantage of when migrating APEX II and APEX 20K designs to Stratix and Stratix GX devices.

Configuration Speed & Schemes

You can configure Stratix and Stratix GX devices at a maximum clock speed of 100 MHz, which is faster than the 66-MHz and 33-MHz maximum configuration speeds for APEX II and APEX 20K devices, respectively. Similar to APEX II devices, you can use 8-bit parallel data to configure Stratix and Stratix GX devices (the target device can receive byte-wide configuration data on each clock cycle) significantly speeding up configuration times.

You can select a configuration scheme based on how the MSEL pins are driven. Stratix and Stratix GX devices have three MSEL pins (APEX II and APEX 20K devices have two MSEL pins) for determining the configuration scheme.



For more information about Stratix and Stratix GX configuration schemes, see the *Configuring Stratix & Stratix GX Devices* chapter.

Remote Update Configuration

The APEX 20K device family introduced the concept of remote update configuration, where you could send the APEX 20K device new configuration files from a remote source and the device would store the files in flash memory and reconfigure itself with the new configuration data. The Stratix and Stratix GX devices enhance support for remote update configuration with new, dedicated circuitry to handle and recover from errors. If an error occurs either during device configuration or in user mode, this new circuitry reconfigures the Stratix or Stratix GX device to a known state. Additionally, the Stratix and Stratix GX devices have a user watchdog timer to ensure the application configuration data executes successfully during user mode. User logic must continually reset this watchdog timer in order to validate that the application configuration data is functioning properly.



For more information about how to use the remote and local update modes, see the *Remote System Configuration with Stratix & Stratix GX Devices* chapter.

JTAG Instruction Support

Stratix and Stratix GX devices support two new JTAG instructions, `PULSE_NCONFIG` and `CONFIG_IO`. The `PULSE_NCONFIG` instruction emulates pulsing the `nCONFIG` signal low to trigger reconfiguration, while the actual `nCONFIG` pin on the device is unaffected. The `CONFIG_IO` instruction allows you to use the JTAG chain to configure I/O standards for all pins. Because this instruction interrupts device configuration, you should reconfigure the Stratix or Stratix GX device after you finish JTAG testing to ensure proper device operation.

[Table 3–13](#) compares JTAG instruction support in Stratix and Stratix GX devices versus APEX II and APEX 20K devices. For further information about the supported JTAG instructions, see the appropriate device family data sheet.

JTAG Instruction	Stratix	APEX II	APEX 20K
SAMPLE/PRELOAD	✓	✓	✓
EXTEST	✓	✓	✓
BYPASS	✓	✓	✓
USERCODE	✓	✓	✓
IDCODE	✓	✓	✓
ICR Instructions	✓	✓	✓

Table 3–13. JTAG Instruction Support (Part 2 of 2)

JTAG Instruction	Stratix	APEX II	APEX 20K
SignalTap™ II Instructions	✓	✓	✓
HIGHZ	✓	✓	
CLAMP	✓	✓	
PULSE_NCONFIG	✓		
CONFIG_IO	✓		

Conclusion

The Stratix and Stratix GX devices extend the advanced features available in the APEX II and APEX 20K device families to deliver a complete system-on-a-programmable-chip (SOPC) solution. By following these guidelines, you can easily transition current APEX II and APEX 20K designs to take advantage of the new features available in Stratix and Stratix GX devices.