



RAM Initializer (ALTMEM_INIT)

Megafunction User Guide



101 Innovation Drive
San Jose, CA 95134
www.altera.com

Software Version: 8.0
Document Version: 1.0
Document Date: May 2008

Copyright © 2008 Altera Corporation. All rights reserved. Altera, The Programmable Solutions Company, the stylized Altera logo, specific device designations, and all other words and logos that are identified as trademarks and/or service marks are, unless noted otherwise, the trademarks and service marks of Altera Corporation in the U.S. and other countries. All other product or service names are the property of their respective holders. Altera products are protected under numerous U.S. and foreign patents and pending applications, maskwork rights, and copyrights. Altera warrants performance of its semiconductor products to current specifications in accordance with Altera's standard warranty, but reserves the right to make changes to any products and services at any time without notice. Altera assumes no responsibility or liability arising out of the application or use of any information, product, or service described herein except as expressly agreed to in writing by Altera Corporation. Altera customers are advised to obtain the latest version of device specifications before relying on any published information and before placing orders for products or services.



UG-01034-1.0



About this User Guide	v
Revision History	v
Referenced Documents	v
How to Contact Altera	v
Typographic Conventions	vi
Chapter 1. About this Megafunction	
Device Family Support	1-1
Introduction	1-1
Features	1-2
General Description	1-3
Chapter 2. Getting Started	
Software and System Requirements	2-1
MegaWizard Plug-In Manager Customization	2-1
MegaWizard Plug-In Manager Page Descriptions	2-2
Instantiating Megafunctions in HDL Code or Schematic Designs	2-8
Generating a Netlist for EDA Tool Use	2-8
Using the Port and Parameter Definitions	2-9
Identifying a Megafunction after Compilation	2-9
Simulation	2-9
Quartus II Software Simulator	2-9
EDA Simulator	2-10
Design Example 1: RAM Initialization with Initialization Data File	2-10
Design Files	2-10
Configuration Settings	2-11
Functional Simulation in the ModelSim-Altera Simulator	2-11
Understanding the Simulation Results	2-12
Design Example 2: Memory Initialization with External ROM	2-15
Design Files	2-15
Configuration Settings	2-16
Functional Simulation in the ModelSim-Altera Simulator	2-16
Understanding the Simulation Results	2-17
Conclusion	2-19
Chapter 3. Specifications	
Ports and Parameters	3-1



About this User Guide

Revision History The following table shows the revision history for this user guide.

Date and Document Version	Changes Made	Summary of Changes
May 2008 v1.0	Initial release.	—

Referenced Documents

This user guide references the following documents:

- *Quartus II Integrated Synthesis* chapter in volume 1 of the *Quartus II Handbook*
- *Recommended HDL Coding Styles* chapter in volume 1 of the *Quartus II Handbook*
- *Simulation* section in volume 3 of the *Quartus II Handbook*
- *Synthesis* section in volume 1 of the *Quartus II Handbook*

How to Contact Altera

For the most up-to-date information about Altera® products, refer to the following table.







Contact (1)	Contact Method	Address
Technical support	Website	www.altera.com/support
Technical training	Website	www.altera.com/training
	Email	custrain@altera.com
Product literature	Website	www.altera.com/literature
Non-technical support (General) (Software Licensing)	Email	nacomp@altera.com
	Email	authorization@altera.com

Note to table:

(1) You can also contact your local Altera sales office or sales representative.

Typographic Conventions

This document uses the typographic conventions shown in the following table.

Visual Cue	Meaning
Bold Type with Initial Capital Letters	Command names, dialog box titles, checkbox options, and dialog box options are shown in bold, initial capital letters. Example: Save As dialog box.
bold type	External timing parameters, directory names, project names, disk drive names, filenames, filename extensions, and software utility names are shown in bold type. Examples: lqdesigns directory, d: drive, chiptrip.gdf file.
<i>Italic Type with Initial Capital Letters</i>	Document titles are shown in italic type with initial capital letters. Example: <i>AN 75: High-Speed Board Design</i> .
<i>Italic type</i>	Internal timing parameters and variables are shown in italic type. Examples: <i>t_{PIA}</i> , <i>n + 1</i> . Variable names are enclosed in angle brackets (< >) and shown in italic type. Example: <file name>, <project name>.pdf file.
Initial Capital Letters	Keyboard keys and menu names are shown with initial capital letters. Examples: Delete key, the Options menu.
“Subheading Title”	References to sections within a document and titles of on-line help topics are shown in quotation marks. Example: “Typographic Conventions.”
Courier type	Signal and port names are shown in lowercase Courier type. Examples: data1, tdi, input. Active-low signals are denoted by suffix n, e.g., resetn. Anything that must be typed exactly as it appears is shown in Courier type. For example: c:\qdesigns\tutorial\chiptrip.gdf. Also, sections of an actual file, such as a Report File, references to parts of files (e.g., the AHDL keyword SUBDESIGN), as well as logic function names (e.g., TRI) are shown in Courier.
1., 2., 3., and a., b., c., etc.	Numbered steps are used in a list of items when the sequence of the items is important, such as the steps listed in a procedure.
	Bullets are used in a list of items when the sequence of the items is not important.
	The checkmark indicates a procedure that consists of one step only.
	The hand points to information that requires special attention.
	A caution calls attention to a condition or possible situation that can damage or destroy the product or the user's work.
	A warning calls attention to a condition or possible situation that can cause injury to the user.
	The angled arrow indicates you should press the Enter key.
	The feet direct you to more information about a particular topic.



Device Family Support

The RAM Initializer (ALTMEM_INIT) megafunction supports the following target Altera® device families:

- ACEX® 1K
- APEX™ II
- APEX 20KC
- APEX 20KE
- Arria™ GX
- Cyclone® III
- Cyclone II
- Cyclone
- FLEX 10K®
- FLEX® 10KA
- FLEX 10KE
- FLEX 6000
- HardCopy® II
- HardCopy Stratix®
- MAX® II
- MAX 3000A
- MAX 7000AE
- MAX 7000B
- MAX 7000S
- Stratix IV
- Stratix III
- Stratix II
- Stratix II GX
- Stratix
- Stratix GX

Introduction

As design complexities increase, the use of vendor-specific intellectual property (IP) blocks has become a common design methodology. Altera provides parameterizable megafunctions that are optimized for Altera device architectures. Using megafunctions instead of coding your own logic saves valuable design time. Additionally, the Altera-provided functions may offer more efficient logic synthesis and device implementation. You can scale the size of the megafunction by setting parameters.

The HardCopy device family does not support the initialization of a random-access memory (RAM) during power-up. The ALTMEM_INIT megafunction addresses this need by providing memory initialization functions for the HardCopy Stratix and HardCopy II devices. The megafunction also supports Stratix devices that are migratable to HardCopy devices, and in general, other Altera devices that come with RAM.

The ALTMEM_INIT megafunction supports multiple RAMs. You can add logic to the output data port of the megafunction to fan out to more than one RAM. For example, if you want to initialize multiple RAMs to contain all zeros, you can connect the appropriate output ports of the ALTMEM_INIT megafunction to the RAMs that you want to initialize.



In this document, HardCopy devices refer to the HardCopy Stratix and HardCopy II devices; Stratix devices refer to the Stratix IV, Stratix III, Stratix II, and Stratix devices.

The ALTMEM_INIT megafunction initializes the RAM of a HardCopy device with the content of a read-only memory (ROM). The ROM can be located internally within the megafunction, or externally in an on-chip or off-chip ROM. During initialization, the megafunction reads the content of the ROM word-by-word and writes it to the RAM. The RAM can also be initialized without the ROM, but the content can only be set to all zeros.



Unless specified otherwise, external ROM refers to both on-chip and off-chip ROM.

Features

The ALTMEM_INIT megafunction provides the following features to implement memory initialization in HardCopy devices:

- Support for RAM initialization using the `INIT_FILE` parameter
- Support for RAM initialization from an external ROM with fixed latency
- Support for RAM initialization from an external ROM with variable latency
- Support for RAM initialization to all zeros
- Status signal to indicate RAM initialization status

These features can be configured easily through the RAM Initializer MegaWizard® Plug-In Manager.



For more information about the `INIT_FILE` parameter, refer to [Chapter 3, Specifications](#).

General Description

The main function of the `ALTMEM_INIT` megafunction is to copy the content of a ROM into the RAM of a HardCopy device. The RAM can be initialized in two modes—the internal-ROM or external-ROM mode. For both modes, initialization begins when you assert the `init` signal.

In the internal-ROM mode, the RAM is initialized with the content of the ROM in the `ALTMEM_INIT` megafunction. This mode uses only the `INIT_FILE` parameter and does not require any connection to the `datain[]` and `rom_address[]` ports.

In the external-ROM mode, the RAM is initialized from either an on-chip or off-chip ROM. The `datain[]` and `rom_address[]` ports of the megafunction must be connected to the external ROM. The initialization process can be automated with a fixed latency by using the `ROM_READ_LATENCY` parameter, or configured with a variable latency by using the `PORT_ROM_DATA_READY` parameter and the `rom_data_ready` control signal.

For the initialization of a RAM from an external ROM with fixed latency, set the `ROM_READ_LATENCY` parameter to the number of delay cycles incurred after the `ALTMEM_INIT` megafunction initiates a read from the ROM. For example, if the ROM has both its input and output ports registered, you can set the clock latency to 2 clock cycles. A fixed latency is usually used for an external on-chip ROM where you can identify the number of delay cycles.

For an off-chip ROM, you may not be able to identify the latency, or the latency may vary for different ROMs. In such cases of variable latency, you can use the `PORT_ROM_DATA_READY` parameter and the `rom_data_ready` signal to control when to read data into the megafunction.

The `ALTMEM_INIT` megafunction can also initialize a RAM without a ROM, but the RAM content can only be set to all zeros. For such an initialization, you do not need to use the `INIT_FILE` parameter or any ROM ports.

The `init_busy` signal of the `ALTMEM_INIT` megafunction reflects the initialization status. You can use this signal as an active-low signal to enable the subsequent processes or as an indicator to show that memory initialization is complete.

Figure 1–1 shows the block diagram of the input and output ports of the ALTMEM_INIT megafunction.

Figure 1–1. Input and Output Ports of ALTMEM_INIT Megafunction

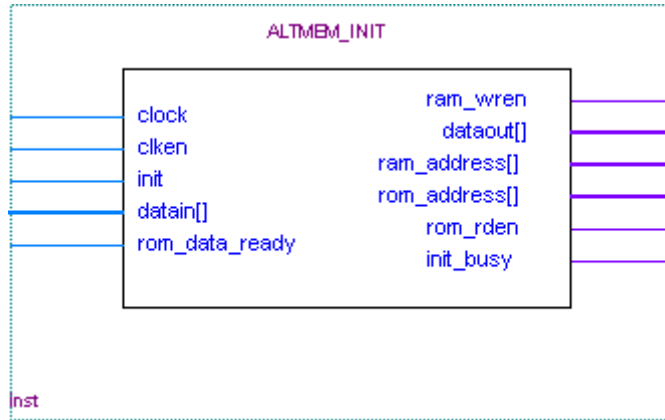

Figure 1–2 shows the block connections for the initialization of a HardCopy device RAM using the INIT_FILE parameter. For this mode, the ROM resides in the ALTMEM_INIT megafunction.

 The block connections in Figure 1–2 also apply to RAM initialization without a ROM.

Figure 1–2. Initializing RAM to All Zeros or with INIT_FILE Parameter

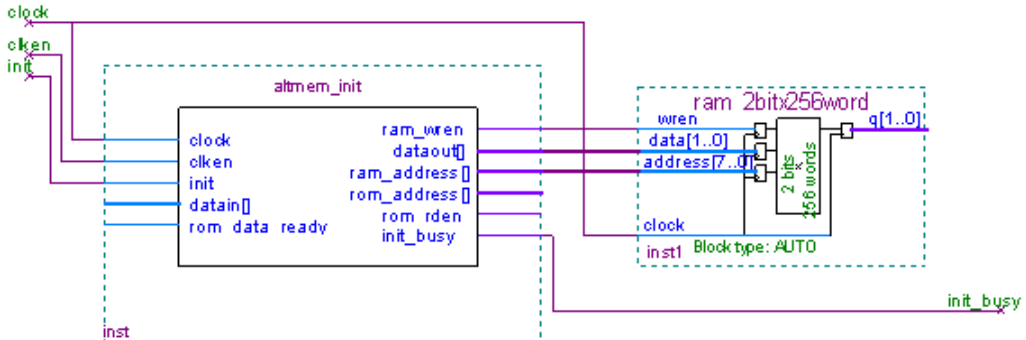
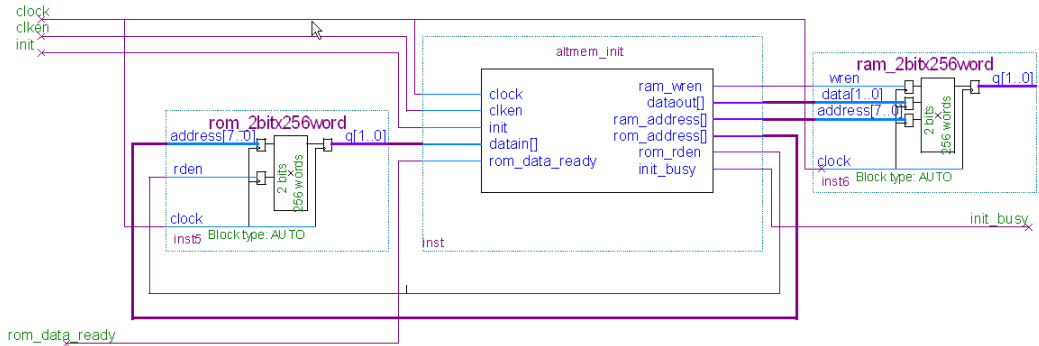

Figure 1–3 shows the block connections for the initialization of a HardCopy device RAM in the external-ROM mode. This mode uses an external on-chip or off-chip ROM.

Figure 1–3. Initializing RAM with External ROM



Software and System Requirements

The instructions in this section require the following software:

- Quartus® II software version 8.0 or later
- For operating system support information, refer to: www.altera.com/support/software/os_support/oss-index.html

MegaWizard Plug-In Manager Customization

The MegaWizard® Plug-In Manager creates or modifies design files that contain custom megafunction variations, which can then be instantiated in a design file. The MegaWizard Plug-In Manager provides a wizard that allows you to specify options for the RAM Initializer (ALTMEM_INIT) megafunction features in your design.



In this document, HardCopy® devices refer to the HardCopy Stratix® and HardCopy II devices; Stratix devices refer to the Stratix IV, Stratix III, Stratix II, and Stratix devices.

Start the MegaWizard Plug-In Manager in one of the following ways:

- On the Tools menu, click **MegaWizard Plug-In Manager**.
- When working in the Block Editor, on the Edit menu, click **Insert Symbol as Block**, or right-click in the Block Editor, point to **Insert**, and click **Symbol as Block**. In the **Symbol** window, click **MegaWizard Plug-In Manager**.
- Start the stand-alone version of the MegaWizard Plug-In Manager by typing the following command at the command prompt:
`qmegawiz ←`

MegaWizard Plug-In Manager Page Descriptions

This section provides descriptions of the options available on the individual pages of the RAM Initializer wizard.

On page 1 of the MegaWizard Plug-In Manager, you can select **Create a new custom megafunction variation**, **Edit an existing custom megafunction variation**, or **Copy an existing custom megafunction variation** (Figure 2-1).

Figure 2-1. MegaWizard Plug-In Manager [page 1]

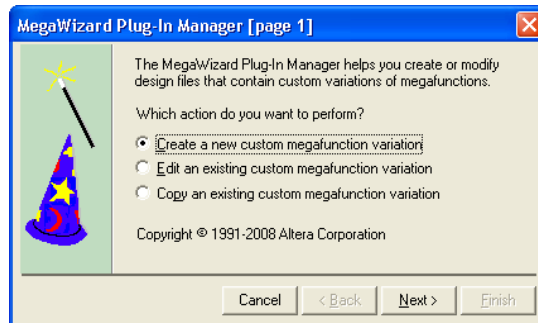

On page 2a of the MegaWizard Plug-In Manager, specify the megafunction, device family to use, the type of output file to create, and the name of the output file (Figure 2-2). Choose AHDL (.tdf), VHDL (.vhd), or Verilog HDL (.v) as the output file type.

Figure 2–2. MegaWizard Plug-In Manager [page 2a]

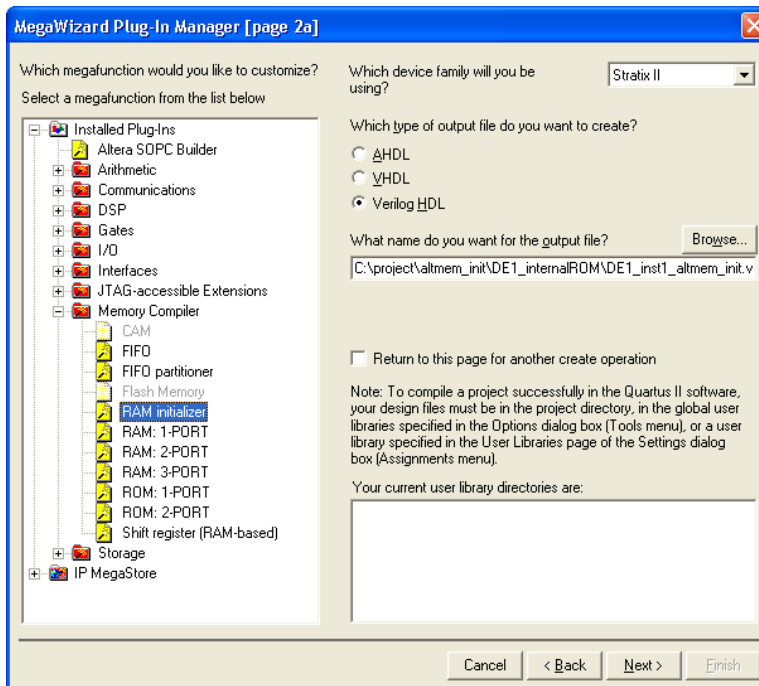

On page 3 of the MegaWizard Plug-In Manager, select the device family and random-access memory (RAM) initialization mode. Next, specify the number of words and data width for the RAM and the read-only memory (ROM) (Figure 2–3).



The message box at the bottom of page 3 of the MegaWizard Plug-In Manager displays the error messages that appear when you specify the wrong configuration settings. You can successfully build the megafunction only after the errors are fixed.

Figure 2-3. RAM Initializer MegaWizard Plug-In Manager [page 3 of 5]

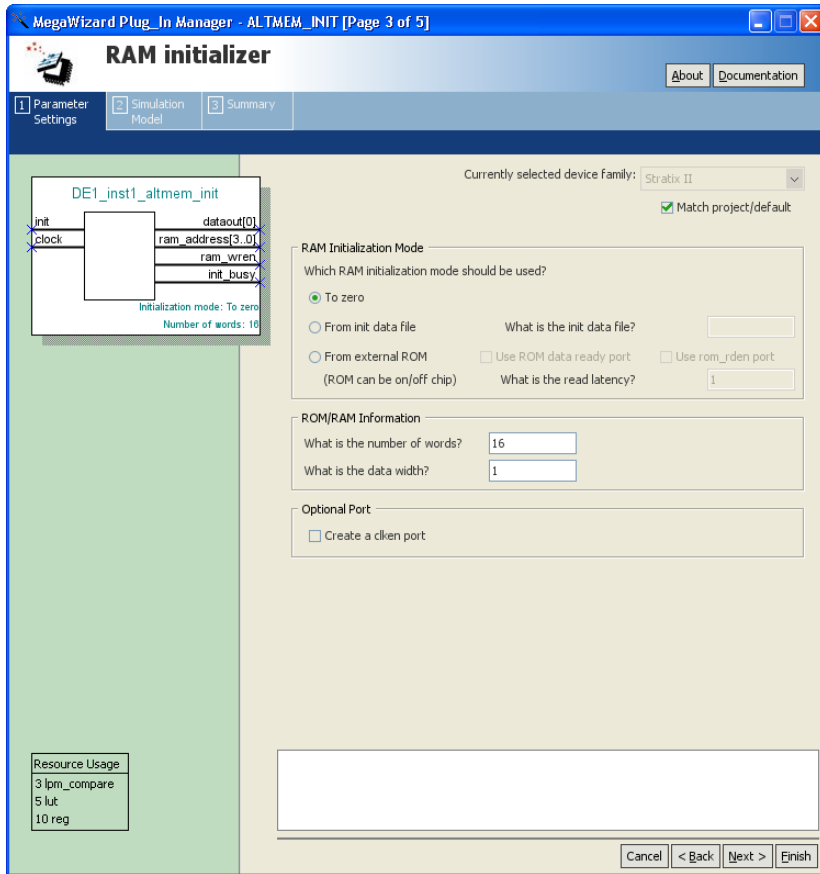

Table 2–1 shows the options available on page 3 of the RAM Initializer MegaWizard Plug-In Manager.

Configuration Setting	Description
Currently selected device family	Select the device family you want to use.
Which RAM initialization mode should be used?	<p>If you want to initialize the RAM to all 0's, select To zero.</p> <p>If you want to initialize the RAM with the <code>INIT_FILE</code> parameter, select From init data file and specify the file name.</p> <p>If you want to initialize the RAM in the external-ROM mode, select From external ROM.</p> <p>Turn on Use ROM data ready port if you want to control the initialization process through the <code>rom_data_ready</code> input port. Turn on Use rom_rden port if the external ROM supports the read-enable port.</p> <p>Turn off Use ROM data ready port if you want to automate the initialization process by specifying the read latency in clock cycles. After initiating a read from the ROM, the <code>ALTMEM_INIT</code> megafunction waits for the specified number of delay cycles before sampling data from the ROM at the subsequent cycle.(1)</p>
What is the number of words?	Specify the number of words (memory depth) for the ROM and the RAM.(2)
What is the data width?	Specify the data width for the ROM and the RAM.
Create a <code>clken</code> port	Turn on this option to create the input port <code>clken</code> , which is used as the clock-enable signal for the megafunction.

Notes to Table 2–1:

- (1) Set the read latency to match the latency, in clock cycles, of the ROM. Set the read latency to 1 clock cycle if only the input port of the ROM is registered. Set the read latency to 2 clock cycles if both the input and output ports of the ROM are registered.
- (2) The number of words for the `ALTMEM_INIT` megafunction to initialize from the ROM to the RAM.

On page 4 of the RAM Initializer MegaWizard Plug-In Manager, you can choose to generate a netlist for your third-party EDA synthesis tool to estimate the timing and resource usage of the megafunction (Figure 2–4).

Figure 2-4. RAM Initializer MegaWizard Plug-In Manager [page 4 of 5]

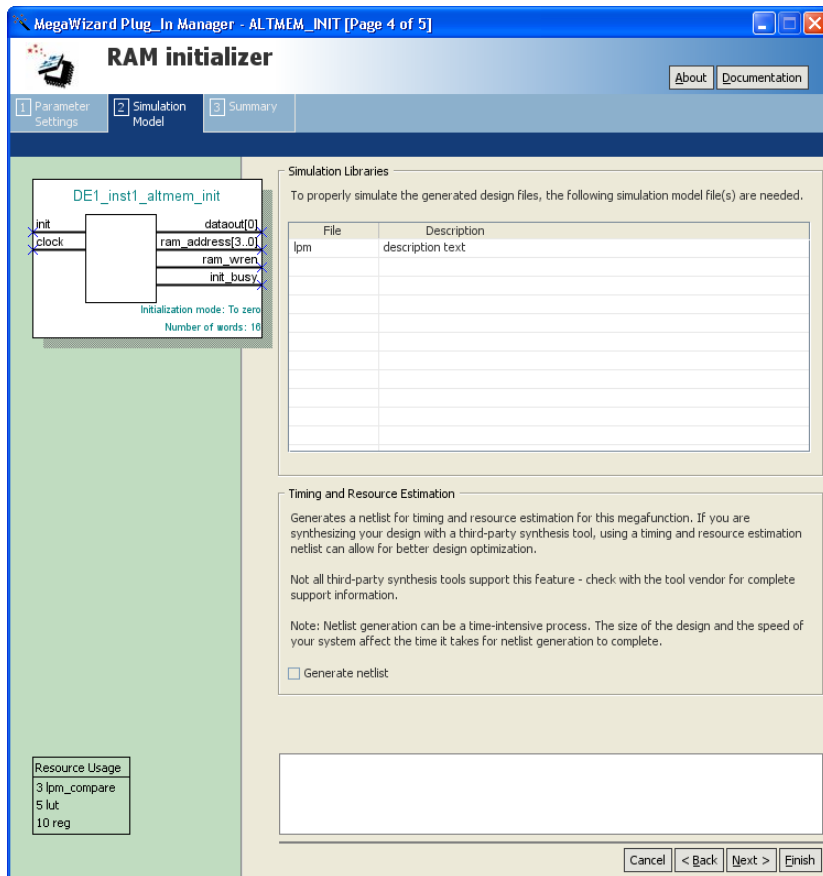

Page 5 of the RAM Initializer MegaWizard Plug-In Manager displays the types of files to be generated. The Variation file, which is automatically generated, contains wrapper code in the language you specified on page 2a. On page 5 of the RAM Initializer MegaWizard Plug-In Manager, specify the types of files to be generated. You can choose from the following types of files:

- Instantiation template file (*<function name>_inst.v*)
- Verilog HDL black-box declaration file (*<function name>_bb.v*)
- AHDL Include file (*<function name>.inc*)
- VHDL component declaration file (*<function name>.cmp*)
- Quartus II symbol file (*<function name>.bsf*)
- Quartus II IP Advisor file (*<function name>.qip*)

Instantiating Megafunctions in HDL Code or Schematic Designs

When you use the MegaWizard Plug-In Manager to customize and parameterize a megafunction, it creates a set of output files that allows you to instantiate the customized function in your design. Depending on the language you choose in the MegaWizard Plug-In Manager, the wizard instantiates the megafunction with the correct parameter values and generates a megafunction variation file (wrapper file) in Verilog HDL (.v), VHDL (.vhd), or AHDL (.tdf), along with other supporting files.

The MegaWizard Plug-In Manager provides options to create the following files:

- A sample instantiation template for the language of the variation file (`_inst.v`, `_inst.vhd`, or `_inst.tdf`)
- Component Declaration File (.cmp) that can be used in VHDL Design Files
- ADHL Include File (.inc) that can be used in Text Design Files (.tdf)
- Quartus II Block Symbol File (.bsf) that can be used in schematic designs
- Verilog HDL module declaration file that can be used when instantiating the megafunction as a black box in a third-party synthesis tool (`_bb.v`)



For more information about the wizard-generated files, refer to Quartus II Help or to the *Recommended HDL Coding Styles* chapter in volume 1 of the *Quartus II Handbook*.

Generating a Netlist for EDA Tool Use

If you use a third-party EDA synthesis tool, you can instantiate the megafunction variation file as a black box for synthesis. Use the VHDL component declaration or Verilog HDL module declaration black-box file to define the function in your synthesis tool, and then include the megafunction variation file in your Quartus II project.

If you enable the option to generate a synthesis area and timing estimation netlist in the MegaWizard Plug-In Manager, the wizard generates an additional netlist file (`_syn.v`). The netlist file is a representation of the customized logic used in the Quartus II software. The file provides the connectivity of the architectural elements in the megafunction but may not represent true functionality. This information enables certain third-party synthesis tools to better report area and timing estimates. In addition, synthesis tools can use the timing information to focus timing-driven optimizations and improve the quality of results.



For more information about using megafunctions in your third-party synthesis tool, refer to the appropriate chapter in the *Synthesis* section in volume 1 of the *Quartus II Handbook*.

Using the Port and Parameter Definitions

Instead of using the MegaWizard Plug-In Manager, you can instantiate the megafunction directly in your Verilog HDL, VHDL, or AHDL code by calling the megafunction and setting its parameters as you would any other module, component, or subdesign.



Altera strongly recommends that you use the MegaWizard Plug-In Manager for complex megafunctions. The MegaWizard Plug-In Manager ensures that you set all megafunction parameters properly.

For a list of the megafunction ports and parameters, refer to [Chapter 3, Specifications](#).

Identifying a Megafunction after Compilation

During compilation with the Quartus II software, analysis and elaboration are performed to build the structure of your design. To locate your megafunction in the **Project Navigator** window, expand the compilation hierarchy and find the megafunction by its name.

To search for node names within the megafunction (using the Node Finder), click **Browse** in the **Look in** box and select the megafunction in the **Hierarchy** box.

Simulation

The Quartus II Simulator provides an easy-to-use, integrated solution for performing simulations. The following sections describe the simulation options.

Quartus II Software Simulator

With the Quartus II Simulator, you can perform two types of simulations: functional and timing. A functional simulation enables you to verify the logical operation of your design without taking into consideration the timing delays in the FPGA or HardCopy device. This simulation is performed using only your RTL code. When performing a functional simulation, add only signals that exist before synthesis. You can find these signals in the Node Finder by using any of the following Filter options: Registers: Pre-Synthesis, Design Entry, or Pins. The top-level ports of megafunctions are found using these three filters.

In contrast, the timing simulation in the Quartus II software verifies the operation of your design with annotated timing information. This simulation is performed using the post place-and-route netlist. When performing a timing simulation, add only signals that exist after place-and-route. These signals are found with the post-compilation filter

of the Node Finder. During synthesis and place-and-route, the names of RTL signals change. Therefore, it may be difficult to find signals from your megafunction instantiation in the post-compilation filter.

To preserve the names of your signals during the synthesis and place-and-route stages, use the synthesis attributes `keep` or `preserve`. These are Verilog HDL and VHDL synthesis attributes that direct analysis and synthesis to keep a particular wire, register, or node intact. Use these synthesis attributes to keep a combinational logic node so you can observe the node during simulation.



For more information about these attributes, refer to the *Quartus II Integrated Synthesis* chapter in volume 1 of the *Quartus II Handbook*.

EDA Simulator

The *Quartus II Handbook* chapters describe how to perform functional and gate-level timing simulations that include the megafunctions, with details about the files that are needed and the directories where the files are located.



Depending on which simulation tool you are using, refer to the appropriate chapter in the *Simulation* section in volume 3 of the *Quartus II Handbook*.

Design Example 1: RAM Initialization with Initialization Data File

This design example uses the `ALTMEM_INIT` megafunction in the MegaWizard Plug-In Manager to initialize the RAM of a HardCopy II device with an initialization data file and the `INIT_FILE` parameter.

Design Files

To initialize the RAM, you can use the `DE1_initfile.mif` file, which is a Memory Initialization File (`.mif`) that contains the content of the internal ROM. You can also create your own `.mif` file using the Quartus II software. The number of words and data width in the `.mif` file must be the same as the corresponding parameter values in the megafunction.

Figure 2–6 shows the content of the initialization data file. In this design example, the file has 16 words, with each word having a data width of 8 bits.

Figure 2–6. Content of the Initialization Data File

Addr	+0	+1	+2	+3	+4	+5	+6	+7	+8	+9	+a	+b	+c	+d	+e	+f
0	12	23	34	45	56	67	78	89	9A	AB	BC	CD	DE	EF	FE	01

A top-level design file, **DE1_top_internalROM.v**, instantiates the ALTMEM_INIT megafunction and the RAM of the HardCopy II device.

The example design files are available in the User Guides section on the Literature page of the Altera® website (www.altera.com).

Configuration Settings

In the RAM Initializer MegaWizard Plug-In Manager pages, select or verify the configuration settings shown in [Table 2–2](#). Click **Next** to advance from one page to the next.

Table 2–2. Design Example 1: Configuration Settings

MegaWizard Plug-In Manager Page	MegaWizard Plug-In Manager Configuration Setting	Value
3	Currently selected device family	HardCopy II
	Which RAM initialization mode should be used?	From init data file
	What is the init data file?	DE1_initfile.mif
	What is the number of words?	16
	What is the data width?	8
	Create a clken port	Selected

Functional Simulation in the ModelSim-Altera Simulator

Simulate the design in the ModelSim®-Altera software to generate a waveform display of the device behavior.

You should be familiar with the ModelSim-Altera software before trying out the design example. If you are unfamiliar with the ModelSim-Altera software, refer to the support page for software products on the Altera website (www.altera.com). On the support page, there are links to such topics as installation, usage, and troubleshooting.

Set up and simulate the design in the ModelSim-Altera software by performing the following steps:

1. Unzip the **DE1_internalROM.zip** file to any working directory on your PC.
2. Start the ModelSim-Altera software.
3. On the File menu, click **Change Directory**.
4. Select the folder in which you unzipped the files.
5. Click **OK**.
6. On the Tools menu, click **Execute Macro**.
7. Select the **DE1_internalROM.do** file and click **Open**. The **DE1_internalROM.do** file is a script file for the ModelSim-Altera software to automate all the necessary settings for the simulation.
8. View the simulation results in the Wave window. **Figure 2–7** shows the expected simulation results in the ModelSim-Altera software.

Figure 2–7. Design Example 1: Simulation Results for RAM Initialization with Initialization Data File

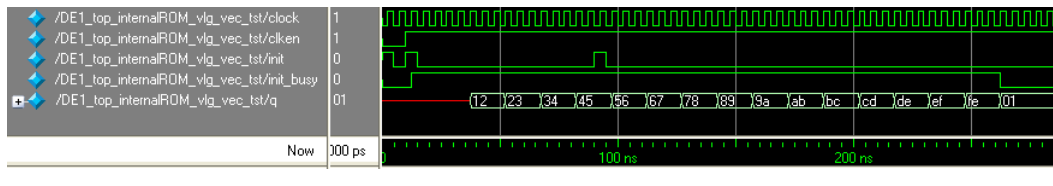

Understanding the Simulation Results

In “[Design Example 1: RAM Initialization with Initialization Data File](#)” on page 2–10, the `ALTMEM_INIT` megafunction initializes the RAM of a HardCopy II device with 16 words—each word having a data width of 8 bits—from an internal ROM using the `DE1_initfile.mif` file.

Figure 2–8 shows the start of initialization after the `init` signal is asserted and the appearance of the first initialization value at the output port of the RAM.

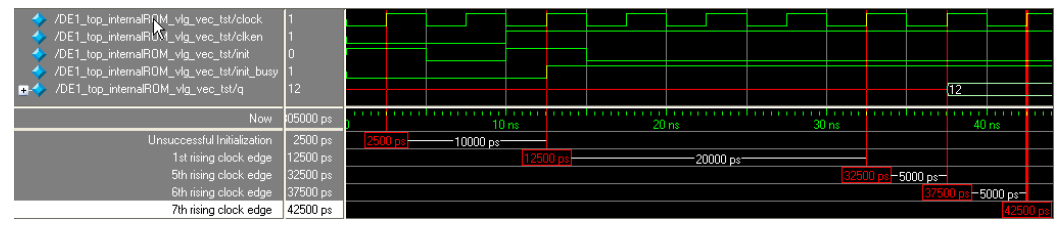
Figure 2–8. Design Example 1: Asserting the init Signal

At 2500 ps, the `init` signal is high, but initialization is unsuccessful because the `clk_en` signal is low. The initialization process can be activated only when both the `clk_en` and `init` signals are high at the rising edge of the clock.

At 12,500 ps, both the `clk_en` and `init` signals are high; therefore, initialization is activated. After initialization is activated, the `init_busy` signal is asserted to indicate that initialization is in progress.



Consider the time when initialization is activated as the first rising edge of the clock.

After the initialization is activated, the first value, 0x12, is written into the RAM at the fifth rising edge of the clock. The value then appears at the output port of the RAM at the sixth rising edge of the clock. The `ALTMEM_INIT` megafunction takes 4 clock cycles to write the first value into the device RAM—3 clock cycles to generate and 1 clock cycle to write the value. The device RAM then takes 1 clock cycle to write the value to its output port, `q`. In total, the output of the first value is delayed by 5 clock cycles upon assertion of the `init` signal.

Figure 2–9 shows the delay cycles of the first write process and subsequent write processes after the `init` signal is asserted.

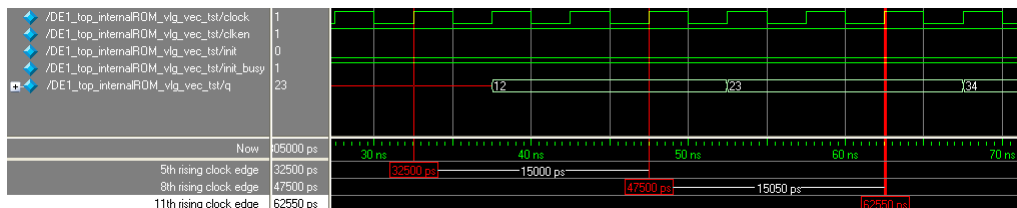
Figure 2–9. Design Example 1: Delay Cycles of First Write Process and Subsequent Write Processes

In Figure 2–9 , the first value, 0x12, is written into the RAM at the fifth rising edge of the clock, delayed by 4 clock cycles. The subsequent values, 0x23 and 0x24, are written at the eighth and eleventh rising edges of the clock, respectively. Both writes are delayed by 3 clock cycles. The rest of the write processes are also delayed by 3 clock cycles each.

Therefore, if your design or application requires an immediate read from the RAM without waiting for the initialization process to complete, you can read the first and subsequent values by taking these delays into consideration. In this design example, for example, you can read the first value at the sixth clock cycle after the `init` signal is asserted, which corresponds to the seventh rising edge of the clock at 42,500 ps. After that, you can read the subsequent values at intervals of 3 clock cycles.

Figure 2–10 shows the assertion of the `init` signal while RAM initialization is still in progress and the `init_busy` signal is high.

Figure 2–10. Design Example 1: Assertion of the `init` Signal While Initialization is Still in Progress

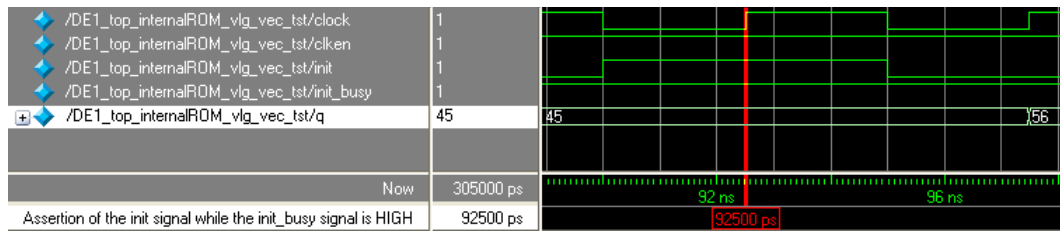

At 92,500 ps, the `init_busy` signal is high to indicate that the initialization of the RAM is still in progress. When the `init` signal is asserted at this point, the initialization process continues uninterrupted. Therefore, the assertion of the `init` signal does not affect the current initialization process while the `init_busy` signal is high. The `init` signal is asserted only once to begin the initialization; to re-initialize the RAM, you must wait until the current initialization is complete.

Figure 2–11 shows the RAM initialization process at completion.

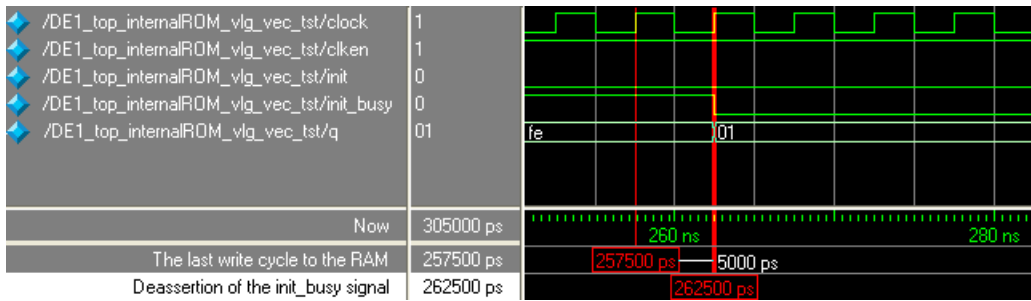
Figure 2–11. Design Example 1: RAM Initialization at Completion

At 257,500 ps, the ALTMEM_INIT megafunction initiates the last write cycle to the RAM. The `init_busy` signal is deasserted during the next rising edge of the clock at 262,500 ps to indicate the end of initialization.

Design Example 2: Memory Initialization with External ROM

This design example uses the ALTMEM_INIT megafunction in the MegaWizard Plug-In Manager to initialize the RAM of a HardCopy II device with an external on-chip ROM.

Design Files

The design files for this example are configured for the external-ROM initialization mode and the latency is fixed with the `ROM_READ_LATENCY` parameter. The RAM of the target HardCopy II device is initialized with the content of an on-chip ROM, located in the device itself.

A top-level design file, `DE2_top_externalROM.v`, instantiates the on-chip ROM, the ALTMEM_INIT megafunction, and the RAM of the HardCopy II device.

Figure 2–12 shows the content of the on-chip ROM. In this design example, the ROM has 16 words, with each word having a data width of 8 bits. The number of words and data width in the ROM are the same as the corresponding parameter values in the megafunction.

Figure 2–12. Content of the On-Chip ROM

Addr	+0	+1	+2	+3	+4	+5	+6	+7	+8	+9	+a	+b	+c	+d	+e	+f
0	11	22	33	44	55	66	77	88	99	AA	BB	CC	DD	EE	FF	1F

The example design files are available in the User Guides section on the Literature page of the Altera website (www.altera.com).

Configuration Settings

In the RAM Initializer MegaWizard Plug-In Manager pages, select or verify the configuration settings shown in [Table 2-3](#). Click **Next** to advance from one page to the next.

MegaWizard Plug-In Manager Page	MegaWizard Plug-In Manager Configuration Setting	Value
3	Currently selected device family	HardCopy II
	Which RAM initialization mode should be used?	From external ROM
	What is the read latency?	2
	What is the number of words?	16
	What is the data width?	8
	Create a <code>clken</code> port	Selected

Functional Simulation in the ModelSim-Altera Simulator

Simulate the design in the ModelSim-Altera software to generate a waveform display of the device behavior.

You should be familiar with the ModelSim-Altera software before trying out the design example. If you are unfamiliar with the ModelSim-Altera software, refer to the support page for software products on the Altera website (www.altera.com). On the support page, there are links to such topics as installation, usage, and troubleshooting.

Set up and simulate the design in the ModelSim-Altera software by performing the following steps:

1. Unzip the **DE2_externalROM.zip** file to any working directory on your PC.
2. Start the ModelSim-Altera software.
3. On the File menu, click **Change Directory**.
4. Select the folder in which you unzipped the files.
5. Click **OK**.

6. On the Tools menu, click **Execute Macro**.
7. Select the **DE2_externalROM.do** file and click **Open**. The **DE2_externalROM.do** file is a script file for the ModelSim-Altera software to automate all the necessary settings for the simulation.
8. View the simulation results in the Wave window. **Figure 2–13** shows the expected simulation results in the ModelSim-Altera software.

Figure 2–13. Design Example 2: Simulation Results for RAM Initialization with External ROM

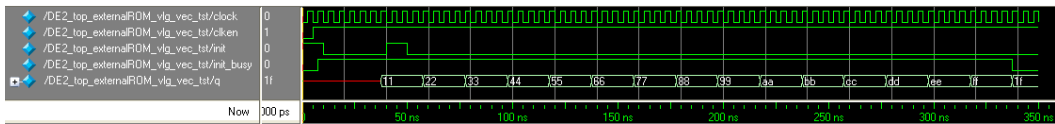

Understanding the Simulation Results

In “[Design Example 2: Memory Initialization with External ROM](#)” on [page 2–15](#), the **ALTMEM_INIT** megafunction initializes the RAM of a **HardCopy II** device with 16 words—each word having a data width of 8 bits—from an external on-chip ROM.

[Figure 2–14](#) shows the start of initialization after the **init** signal is asserted and the appearance of the first initialization value at the output port of the RAM.

Figure 2–14. Design Example 2: Asserting the init Signal

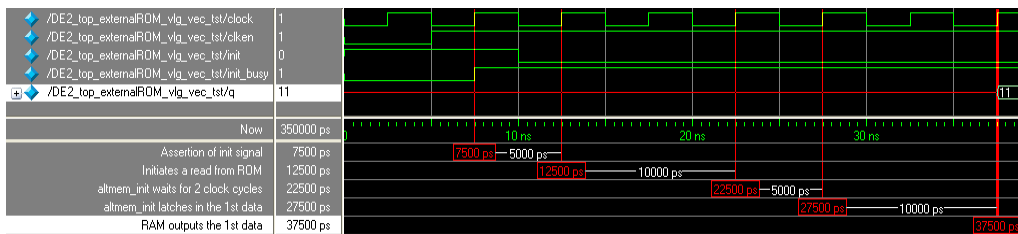

At 7500 ps, initialization is activated and the **init_busy** signal asserted to indicate that the initialization is in progress.



Consider the time when initialization is activated as the first rising edge of the clock.

At the second rising edge of the clock at 12,500 ps, the `ALTMEM_INIT` megafunction initiates a read from the ROM. Both the address input port and data output port of the external on-chip ROM are registered; therefore, the value of the `ROM_READ_LATENCY` parameter is set to 2. With this setting, the `ALTMEM_INIT` megafunction waits 2 clock cycles, from 12,500 ps to 22,500 ps, before sampling data at the next rising edge of the clock at 27,500 ps.



If the ROM does not have any registered output ports, set the `ROM_READ_LATENCY` parameter to 1.

As both the input and output ports of the RAM are also registered, there is a delay of another 2 clock cycles before the value appears at the output port of the RAM at 37,500 ps.

In total, upon assertion of the `init` signal, the first value is delayed by 6 clock cycles before showing up at the output port of the RAM.

Figure 2–15 shows the delay cycles of the first value and subsequent values that appear at the RAM output port after the `init` signal is asserted.

Figure 2–15. Design Example 2: Delay Cycles of First Value and Subsequent Values at the RAM Output Port

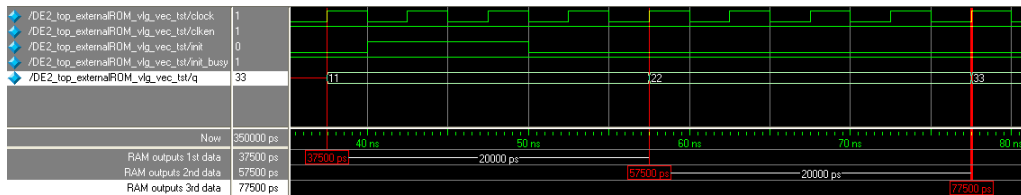

In Figure 2–15, the RAM sends the first value, `0x11`, to its output port after 6 clock cycles. The subsequent values, `0x22` and `0x33`, are delayed by 4 clock cycles—2 clock cycles for the ROM read latency and another 2 clock cycles for the value to appear at the output port of the RAM.

Therefore, if your design or application needs to read from the RAM without waiting for the initialization process to complete, you can read the first and subsequent values by taking these delays into consideration. In this design example, for example, you can read the first value at the seventh clock cycle after the `init` signal is asserted. After that, you can read the subsequent values at intervals of 4 clock cycles.

Figure 2–15 also shows that the assertion of the `init` signal does not affect the current initialization process while the `init_busy` signal is high. The `init` signal is asserted only once to begin the initialization; to re-initialize the RAM, you must wait until the current initialization is complete.

Figure 2–16 shows the RAM initialization process at completion.

Figure 2–16. Design Example 2: RAM Initialization at Completion

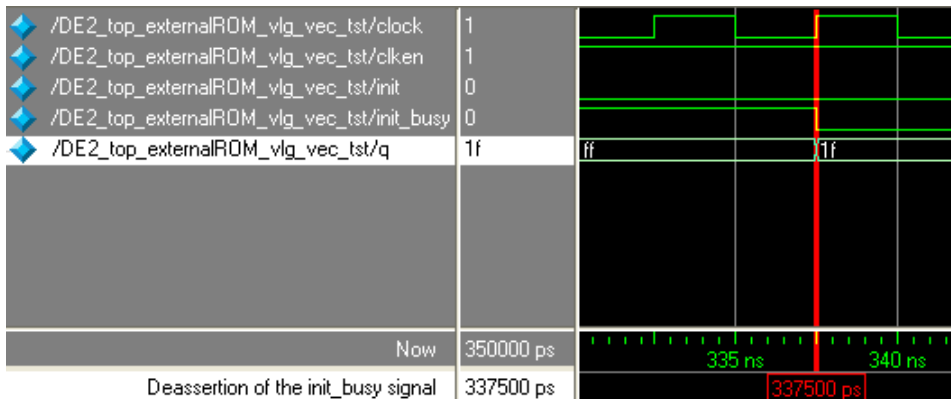

At 337,500 ps, the last value, 0x1f, appears at the output port of the RAM. The `init_busy` signal is deasserted to indicate the end of initialization.

If the external ROM has both its input and output ports registered, and the `ROM_READ_LATENCY` is set to 1, the last initialization data is not written to the RAM.

Conclusion

The `ALTMEM_INIT` megafunction is designed specifically to support the RAM initialization in HardCopy devices and Stratix devices that are migratable to HardCopy devices. You can also use it for other Altera devices that come with RAM.

The megafunction offers different initialization modes with either an initialization data file or an external ROM, providing you with the flexibility to choose a mode that suits your application. You can also select the appropriate latency mode to control the initialization process according to your design specifications.

Ports and Parameters

The Quartus® II software provides the RAM Initializer (ALTMEM_INIT) megafunction to initialize the random-access memory (RAM) of a device with the content of a read-only memory (ROM). The ROM can be located internally within the megafunction, or externally in an on-chip or off-chip ROM. This chapter describes the ports and parameters of the ALTMEM_INIT megafunction. These ports and parameters are available to customize the ALTMEM_INIT megafunction according to your application.

 In this document, HardCopy® devices refer to the HardCopy Stratix® and HardCopy II devices; Stratix devices refer to the Stratix IV, Stratix III, Stratix II, and Stratix devices.

 Unless specified otherwise, external ROM refers to both on-chip and off-chip ROM.

The parameter details are only relevant for users who bypass the MegaWizard® Plug-In Manager interface and use the megafunction as a directly parameterized instantiation in their design. The details of these parameters are hidden from the user of the MegaWizard Plug-In Manager interface.



Refer to the latest version of the Quartus II Help for the most current information on the ports and parameters for this megafunction.

Figure 3–1 shows the input and output ports for the ALTMEM_INIT megafunction.

Figure 3–1. Input and Output Ports of the ALTMEM_INIT Megafunction

Table 3–1 shows the input ports, Table 3–2 shows the output ports, and Table 3–3 shows the parameters for the ALTMEM_INIT megafunction.

Port Name	Required	Description	Comments
clock	Yes	Write clock for RAM. Read clock for ROM.	—
clken	No	Clock enable port.	Values are 0 (disabled) and 1 (enabled). If omitted, the default value is 1.
datain[]	No	Data input from external ROM.	Input port [(width–1)..0] wide. This port is applicable in the external-ROM mode only.
init	Yes	When asserted, this signal directs the megafunction to begin initializing from ROM.	—
rom_data_ready	No	Input port for external-ROM mode.	When the PORT_ROM_DATA_READY parameter value is set to PORT_USED, the rom_data_ready port is used in the external-ROM mode. Assert this signal for each word of data when the ALTMEM_INIT megafunction is ready to read the data.

Table 3–2 lists the output ports of the ALTMEM_INIT megafunction.

Port Name	Required	Description	Comments
dataout []	Yes	Data sent to external RAM.	Output port [(width–1)..0] wide. The value of the dataout port corresponds to the data at the address specified by the ram_address port.
init_busy	Yes	Indicates that the RAM initialization from ROM is in progress.	The init_busy signal remains active throughout the initialization process, and returns to an inactive state when initialization is complete.
ram_wren	Yes	Write-enable signal to RAM.	When asserted, the data that is sent from the dataout port is valid.
ram_address []	Yes	RAM address.	—
rom_address []	No	ROM address that connects to the external ROM.	This port is applicable in the external-ROM mode only. When this port is in use, connect it to the address input port of the external ROM.
rom_rden	No	Read-enable signal that connects to the external ROM.	This port is applicable in the external-ROM mode only. When asserted, the ALTMEM_INIT megafunction generates valid values for the rom_address port.

Table 3–3 lists the parameters for the ALTMEM_INIT megafunction.

Parameter Name	Type	Required	Description
INIT_FILE	String	No	Specifies the name of the initialization file. If the INIT_FILE parameter is specified, the INIT_TO_ZERO parameter value is overridden and initialization from internal ROM is performed. If the INIT_FILE and INIT_TO_ZERO parameter values are not specified, initialization from an external ROM address is performed. You must connect the appropriate ports when initialization is from an external ROM address.
INIT_TO_ZERO	String	No	Specifies whether the RAM must be initialized to contain all 0's. The INIT_FILE parameter value takes precedence over the INIT_TO_ZERO parameter value. Values are YES and NO. If omitted, the default is NO.

Table 3–3. ALTMEM_INIT Megafunction Parameters (Part 2 of 2)

Parameter Name	Type	Required	Description
NUMWORDS	Integer	Yes	Number of words stored in the ROM and the RAM.
ROM_READ_LATENCY	Integer	No	Specifies the number of cycles to wait after the ALTMEM_INIT megafunction sends a read address to the ROM to initialize a read. The value of the ROM_READ_LATENCY parameter must reflect the latency in clock cycles induced by the registers in the external ROM. For example, if the ROM has both its input and output ports registered, set this parameter to 2. This parameter is valid only in the external-ROM mode.
PORT_ROM_DATA_READY	String	No	Specifies whether the rom_data_ready port is used. Values are PORT_USED and PORT_UNUSED. If omitted, the default value is PORT_UNUSED. When the ALTMEM_INIT megafunction is in the external-ROM mode and the rom_data_ready input port is used, set the PORT_ROM_DATA_READY parameter to PORT_USED.
WIDTHAD	Integer	Yes	Width of the ROM and the RAM.
WIDTH	Integer	Yes	Data width of the ROM and the RAM.