

Product Highlights

- High memory throughput achieved via Look-Ahead command processing, Bank Management and Auto-Precharge support
- Multi-Port Front-End supports high efficiency command reordering and multi-port interface
- ECC, RMW, and Multi-Burst add-on modules available
- Achieves high clock rates with minimal routing constraints
- Supports all standard DDR SDRAM chips and DIMMs
- Run-time configurable timing parameters and memory settings
- A variety of read capture options are supported
- Automatic generation of initialization and refresh sequences
- Supports self-refresh and power-down modes
- Source code available
- Customization and Integration services available

Block Diagram

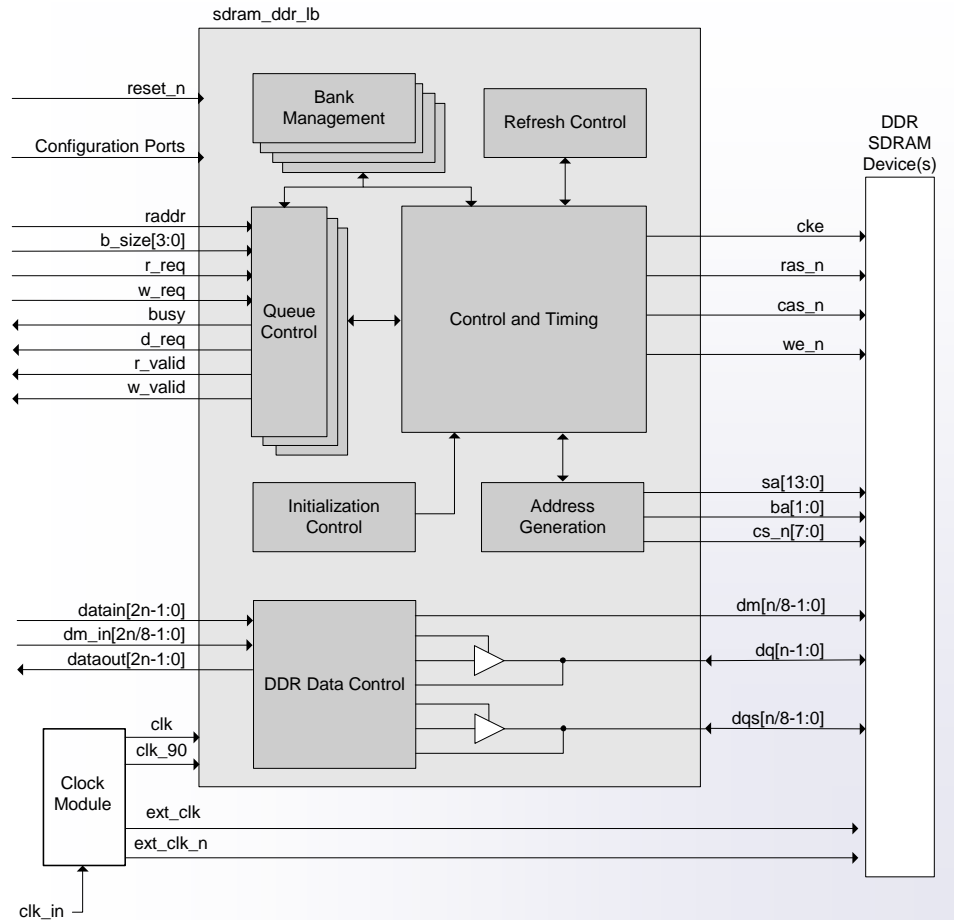

Product Overview

Northwest Logic's Double Data Rate (DDR) SDRAM Controller Core is designed for use in applications requiring high memory throughput, high clock rates and full programmability.

The core accepts commands using a simple local interface and translates them to the command sequences required by DDR SDRAM devices. The core also performs all initialization and refresh functions.

The core uses bank management modules to monitor the status of each SDRAM bank. Banks are only opened or closed when necessary, minimizing access delays. Up to sixteen banks can be managed at one time.

The core queues up multiple commands in the command queue. This enables optimal bandwidth utilization for both short transfers to highly random address locations as well as longer transfers to contiguous address space. The command queue is also used to opportunistically perform look-ahead activates, precharges and auto-precharges further improving overall throughput.

The core is provided with run-time programmable inputs for all

memory timing parameters and configuration settings. This ensures compatibility with all DDR SDRAM configurations.

Four optional add-on modules are available:

- Multi-Port Front-End
- Error Correction Coding (ECC) Module
- Read-Modify-Write (RMW) Module
- Multi-Burst Module

Northwest Logic also provides customization and integration services to produce complete logic designs.

Product Deliverables:

- Core (Netlist or Source Code)
- Comprehensive Verification Suite (Source Code)
- Complete Documentation
- Expert Technical Support & Maintenance Updates