

Introduction

To meet the demand for higher system speed in data communications, semiconductor vendors use increasingly advanced processing technologies requiring lower operating voltages. As a result, printed circuit boards (PCBs) often incorporate devices conforming to one of several voltage level I/O standards, such as 3.3-V, 2.5-V, 1.8-V and 1.5-V. A mixture of components with various voltage level I/O standards on a single PCB is inevitable.

In order to accommodate this mixture of devices on a single PCB, a device that can act as a bridge or interface between these devices is needed. The Cyclone® device family's MultiVolt™ I/O operation capability meets the increasing demand for compatibility with devices of different voltages. MultiVolt I/O operation separates the power supply voltage from the output voltage, enabling Cyclone devices to interoperate with other devices using different voltage levels on the same PCB.

In addition to MultiVolt I/O operation, this chapter discusses several other features that allow you to use Cyclone devices in multiple-voltage systems without damaging the device or the system, including:

- Hot-Socketing—add and remove Cyclone devices to and from a powered-up system without affecting the device or system operation
- Power-Up Sequence flexibility—Cyclone devices can accommodate any possible power-up sequence
- Power-On Reset—Cyclone devices maintain a reset state until voltage is within operating range

I/O Standards

The I/O buffer of a Cyclone device is programmable and supports a wide range of I/O voltage standards. Each I/O bank in a Cyclone device can be programmed to comply with a different I/O standard. All I/O banks can be configured with the following I/O standards:

- 3.3-V LVTTTL/LVCMOS
- 2.5-V LVTTTL/LVCMOS
- 1.8-V LVTTTL/LVCMOS
- 1.5-V LVCMOS
- LVDS
- SSTL-2 Class I and II
- SSTL-3 Class I and II

I/O banks 1 and 3 also include 3.3-V PCI I/O standard interface capability. See Figure 11–1.

Figure 11–1. I/O Standards Supported by Cyclone Devices Notes (1), (2), (3)

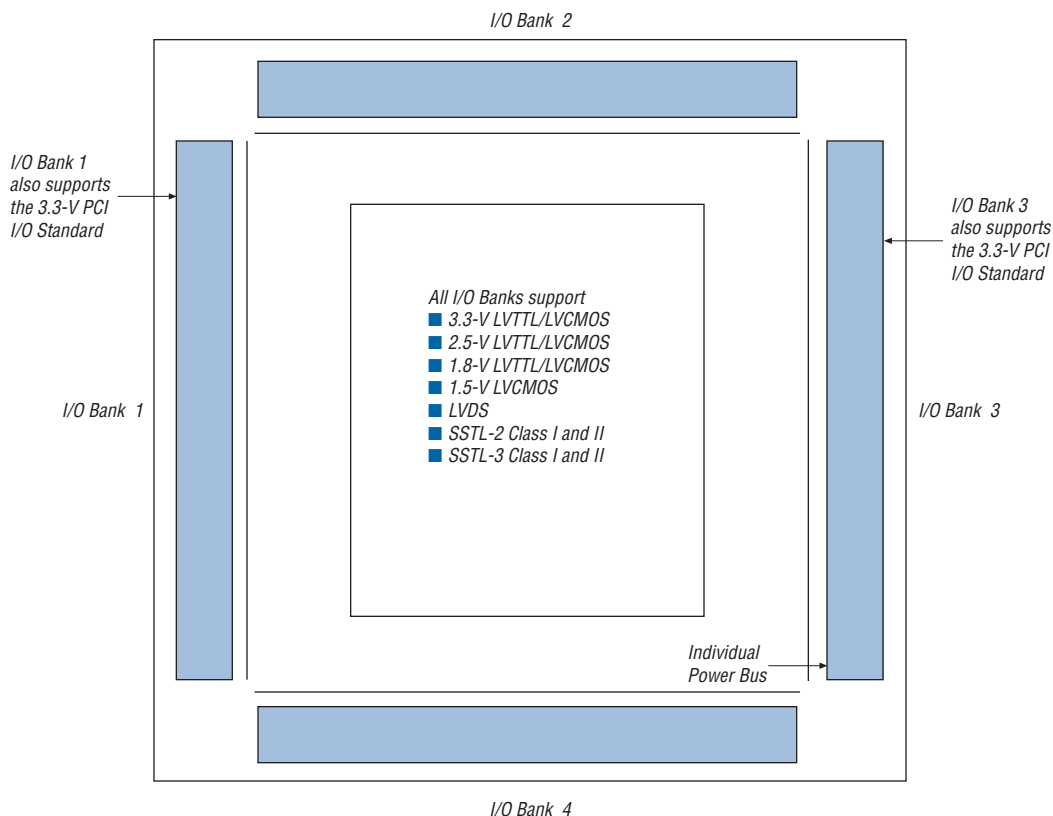

Notes to Figure 11–1

- (1) Figure 1 is a top view of the silicon die.
- (2) Figure 1 is a graphical representation only. Refer to the pin list and the Quartus® II software for exact pin locations.
- (3) The EP1C3 device in the 100-pin thin quad flat pack (TQFP) package does not have support for a PLL LVDS input or an external clock output.

MultiVolt I/O Operation

Cyclone devices include MultiVolt I/O operation capability, allowing the core and I/O blocks of the device to be powered-up with separate supply voltages. The VCCINT pins supply power to the device core and the VCCIO pins supply power the device's I/O buffers.



Supply all device V_{CCIO} pins that have MultiVolt I/O capability at the same voltage level (e.g., 3.3-V, 2.5-V, 1.8-V, or 1.5-V). See [Figure 11-2](#).

Figure 11-2. Implementing a Multiple-Voltage System with a Cyclone Device

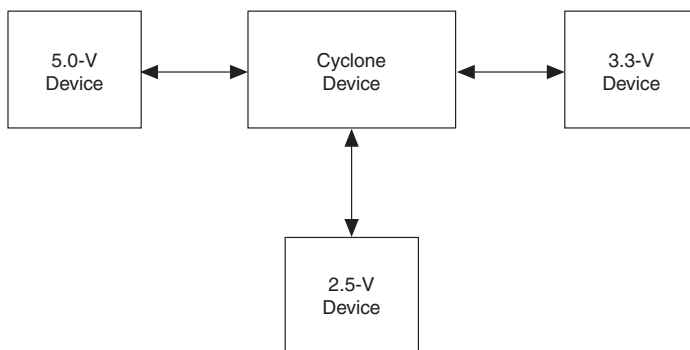

5.0-V Device Compatibility

A Cyclone device may not correctly interoperate with a 5.0-V device if the output of the Cyclone device is connected directly to the input of the 5.0-V device. If V_{OUT} of the Cyclone device is greater than V_{CCIO} , the PMOS pull-up transistor still conducts if the pin is driving high, preventing an external pull-up resistor from pulling the signal to 5.0-V.

A Cyclone device can drive a 5.0-V LVTTTL device by connecting the V_{CCIO} pins of the Cyclone device to 3.3 V. This is because the output high voltage (V_{OH}) of a 3.3-V interface meets the minimum high-level voltage of 2.4-V of a 5.0-V LVTTTL device. (A Cyclone device cannot drive a 5.0-V LVCMOS device.)

Because the Cyclone devices are 3.3-V, 64- and 32-bit, 66- and 33-MHz PCI compliant the input circuitry accepts a maximum high-level input voltage (V_{IH}) of 4.1-V. To drive a Cyclone device with a 5.0-V device, you must connect a resistor (R_2) between the Cyclone device and the 5.0-V device. See [Figure 11-3](#).

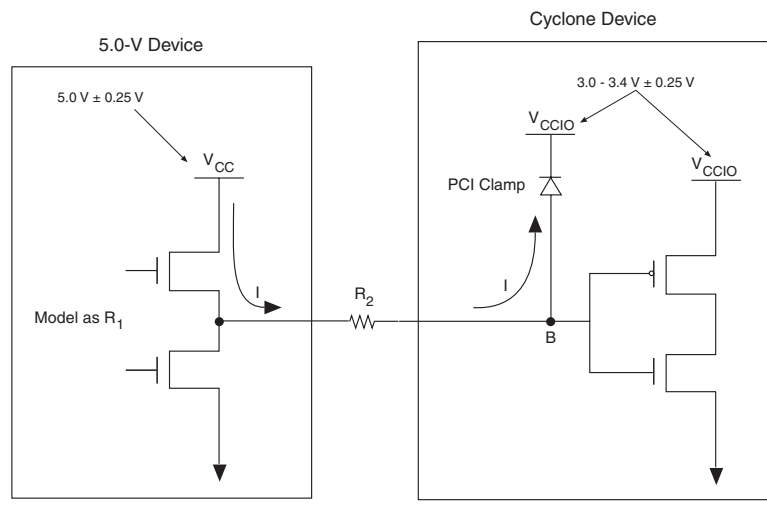
Figure 11–3. Driving a Cyclone Device with a 5.0-Volt Device

If V_{CCIO} is between 3.0-V and 3.6-V and the PCI clamping diode (not available on EP1C3 devices) is enabled, the voltage at point B in [Figure 11–3](#) is 4.3-V or less. To limit large current draw from the 5.0-V device, R_2 should be small enough for a fast signal rise time and large enough so that it does not violate the high-level output current (I_{OH}) specifications of the devices driving the trace. The PCI clamping diode in the Cyclone device can support 25mA of current.

To compute the required value of R_2 , first calculate the model of the pull-up transistors on the 5.0-V device. This output resistor (R_1) can be modeled by dividing the 5.0-V device supply voltage (V_{CC}) by the I_{OH} :

$$R_1 = V_{CC}/I_{OH}$$

[Figure 11–4](#) shows an example of typical output drive characteristics of a 5.0-V device.

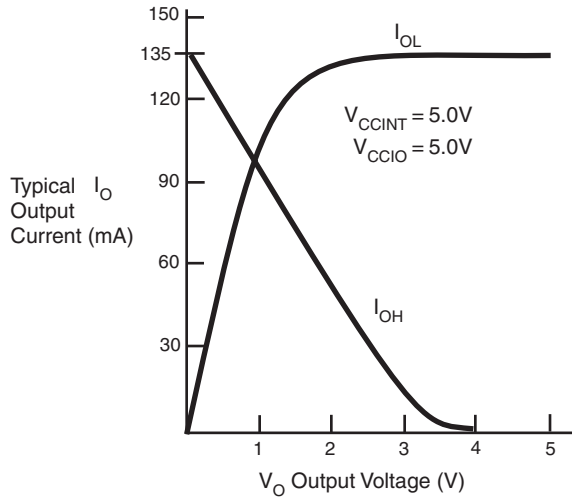
Figure 11–4. Output Drive Characteristics of a 5.0-V Device

As shown above, $R_1 = 5.0\text{-V}/135\text{ mA}$.



The values usually shown in data sheets reflect typical operating conditions. Subtract 20% from the data sheet value for guard band. This subtraction applied to the above example gives R_1 a value of $30\ \Omega$

R_2 should be selected to not violate the driving device's I_{OH} specification. For example, if the above device has a maximum I_{OH} of 8 mA, given the PCI clamping diode, $V_{IN} = V_{CCIO} + 0.7\text{-V} = 3.7\text{-V}$. Given that the maximum supply load of a 5.0-V device (V_{CC}) will be 5.25-V, the value of R_2 can be calculated as follows:

$$R_2 = \frac{(5.25\text{V} - 3.7\text{ V}) - (8\text{ mA} \times 30\ \Omega)}{8\text{ mA}} = 164\ \Omega$$

This analysis assumes worst-case conditions. If your system will not see a wide variation in voltage-supply levels, you can adjust these calculations accordingly.



Because 5.0-V device tolerance in Cyclone devices requires use of the PCI clamp (not available on EP1C3 devices), and this clamp is activated during configuration, 5.0-V signals may not be driven into the device until it is configured.

Hot-Socketing

Hot-socketing, also known as hot-swapping, refers to inserting or removing a board or device into or out of a system board while system power is on. For a system to support hot-socketing, plug-in or removal of the subsystem or device must not damage the system or interrupt system operation.

All devices in the Cyclone family are designed to support hot-socketing without special design requirements. The following features have been implemented in Cyclone devices to facilitate hot-socketing:

- Devices can be driven before power-up with no damage to the device.
- I/O pins remain tri-stated during power-up.
- Signal pins do not drive the V_{CCIO} or V_{CCINT} power supplies.



Because 5.0-V tolerance in Cyclone devices require the use of the PCI clamping diode, and the clamping diode is only available after configuration has finished, be careful not to connect 5.0-V signals to the device.

Devices Can Be Driven before Power-Up

The device I/O pins, dedicated input pins, and dedicated clock pins of Cyclone devices can be driven before or during power-up without damaging the devices.

I/O Pins Remain Tri-Stated during Power-Up

A device that does not support hot-socketing may interrupt system operation or cause contention by driving out before or during power-up. For Cyclone devices, I/O pins are tri-stated before and during power-up and configuration, and will not drive out.

Signal Pins Do Not Drive the V_{CCIO} or V_{CCINT} Power Supplies

A device that does not support hot-socketing will short power supplies together when powered-up through its signal pins. This irregular power-up can damage both the driving and driven devices and can disrupt card power-up.

In Cyclone devices, there is no current path from I/O pins, dedicated input pins, or dedicated clock pins to the V_{CCIO} or V_{CCINT} pins before or during power-up. A Cyclone device may be inserted into (or removed from) a powered-up system board without damaging or interfering with system-board operation. When hot-socketing, Cyclone devices have a minimal effect on the signal integrity of the backplane.



The maximum DC current when hot-socketing Cyclone devices is less than 300 μA , whereas the maximum AC current during hot-socketing is less than 8 mA for a period of 10ns or less.

During hot-socketing, the signal pins of a device may be connected and driven by the active system before the power supply can provide current to the device V_{CC} and ground planes. Known as latch-up, this condition can cause parasitic diodes to turn on within the device, causing the device to consume a large amount of current, and possibly causing electrical damage. This operation can also cause parasitic diodes to turn on inside of the driven device. Cyclone devices are immune to latch-up when hot-socketing.

Power-Up Sequence

Because Cyclone devices can be used in a multi-voltage environment, they are designed to tolerate any possible power-up sequence. Either V_{CCINT} or V_{CCIO} can initially supply power to the device, and 3.3-V, 2.5-V, 1.8-V, or 1.5-V input signals can drive the devices without special precautions before V_{CCINT} or V_{CCIO} is applied. Cyclone devices can operate with a V_{CCIO} voltage level that is higher than the V_{CCINT} level. You can also change the V_{CCIO} supply voltage while the board is powered-up. However, you must ensure that the V_{CCINT} and V_{CCIO} power supplies stay within the correct device operating conditions.

When V_{CCIO} and V_{CCINT} are supplied from different power sources to a Cyclone device, a delay between V_{CCIO} and V_{CCINT} may occur. Normal operation does not occur until both power supplies are in their recommended operating range. When V_{CCINT} is powered-up, the IEEE Std. 1149.1 Joint Test Action Group (JTAG) circuitry is active. If TMS and TCK are connected to V_{CCIO} and V_{CCIO} is not powered-up, the JTAG signals are left floating. Thus, any transition on TCK can cause the state machine to transition to an unknown JTAG state, leading to incorrect operation when V_{CCIO} is finally powered-up. To disable the JTAG state during the power-up sequence, TCK should be pulled low to ensure that an inadvertent rising edge does not occur on TCK.

Power-On Reset

When designing a circuit, it is important to consider system state at power-up. Cyclone devices maintain a reset state during power-up. When power is applied to a Cyclone device, a power-on-reset event occurs if V_{CC} reaches the recommended operating range within a certain period of time (specified as a maximum V_{CC} rise time). A POR event does not occur if these conditions are not met because slower rise times can cause incorrect device initialization and functional failure. The V_{CCIO} level of the I/O banks that contains configuration pins must also reach an acceptable level to trigger POR event.



If V_{CCINT} does not remain in the specified operating range, operation is not assured until V_{CCINT} re-enters the range.

Conclusion

PCBs often contain a mix of 5.0-V, 3.3-V, 2.5-V, 1.8-V, and 1.5-V devices. The Cyclone device family's MultiVolt I/O operation capability allows you to incorporate newer-generation devices with devices of varying voltage levels. This capability also enables the device core to run at its core voltage, V_{CCINT} , while maintaining I/O pin compatibility with other logic levels. Altera has taken further steps to make system design easier by designing devices that allow V_{CCINT} and V_{CCIO} to power-up in any sequence and by incorporating support for hot-socketing.

Document Revision History

Table 11-1 shows the revision history for this chapter.

Date and Document Version	Changes Made	Summary of Changes
May 2008 v1.3	Minor textual and style changes.	—
January 2007 v1.2	Updated "Power-On Reset" section.	—
October 2003 v1.1	Added 64-bit PCI support information.	—
May 2003 v1.0	Added document to Cyclone Device Handbook.	—